

ED 022 912

FINANCIAL MANAGEMENT REQUIREMENTS FOR BUREAU OF WORK PROGRAMS SPONSORS.

Manpower Administration (DOL), Washington, D.C.

Pub Date 68

Note- 110p.

EDRS Price MF-\$0.50 HC-\$4.48

Descriptors- *ACCOUNTING, ADMINISTRATOR GUIDES, EDUCATIONAL PROGRAMS, *FEDERAL PROGRAMS, FINANCIAL POLICY, *RECORDKEEPING, *RECORDS (FORMS), *WORK EXPERIENCE PROGRAMS, YOUTH PROGRAMS

This handbook was developed for use by sponsors of Bureau of Work Programs such as Operation Mainstream, New Careers, Special Impact Programs, Work Experience Programs, Concentrated Employment Programs and Community Action Programs. Included are the audit requirements of the Manpower Administration, an accounting manual designed for effective financial record control, and a proposed system for the construction and maintenance of personal property records. Chapter I states the Bureau's minimum requirements for the control of and accounting for its funds, Chapter II provides a uniform system of accounts, procedures for maintaining and recording costs, revenue, and other financial transactions, and a means of developing and maintaining financial and statistical data which support the sponsor's invoices and are necessary for cost reports. Chapter III spells out the technique of controlling personal property through an asset account in the general ledger. The appendix gives a flow chart and sample set of records. Sample record forms are given throughout the handbook. (EM)

U.S. DEPARTMENT OF HEALTH, EDUCATION & WELFARE
OFFICE OF EDUCATION

**FINANCIAL
MANAGEMENT
REQUIREMENTS
FOR BUREAU
OF WORK
PROGRAMS
SPONSORS**

THIS DOCUMENT HAS BEEN REPRODUCED EXACTLY AS RECEIVED FROM THE
PERSON OR ORGANIZATION ORIGINATING IT. POINTS OF VIEW OR OPINIONS
STATED DO NOT NECESSARILY REPRESENT OFFICIAL OFFICE OF EDUCATION
POSITION OR POLICY.

U.S. DEPARTMENT OF LABOR
MANPOWER ADMINISTRATION

ED 022 912

VT005955

MEMORANDUM TO SPONSORS OF BUREAU OF WORK PROGRAMS

This handbook has been developed to help sponsors of the Bureau of Work Programs to develop and maintain the accounting systems necessary under agreements with the U.S. Government.

Incorporated in this handbook are the audit requirements necessary to meet the auditing standards of the Manpower Administration of the U.S. Department of Labor; an accounting manual designed to portray the accounting approaches to sound and effective financial record control; and a proposed system for the construction and maintenance of personal property records.

The specific records and accounting techniques discussed in this handbook are not imposed as requirements on every sponsor. This point is made clear in the body of the handbook. What is required, however, is a system of documentation control and the reflection of all transactions in a set of records susceptible to audit by the U.S. General Accounting Office, by the Audit Staff of the Department of Labor, or by an independent accounting firm. The nature of the Bureau of Work Programs agreements requires a detailed accounting of all federally-financed and in-kind expenses without exception. Therefore the accounting principles set forth in the auditing requirements must be observed by every sponsor. It is of the utmost importance that reports from sponsors be submitted regularly on an accurate and timely basis.

Further information about this proposed accounting system or explanation of the related auditing requirements may be obtained from:

Chief, Division of Finance
Office of Financial and Management Services
Manpower Administration
U.S. Department of Labor
14th and Constitution Avenue, N.W.
Washington, D.C. 20210

TABLE OF CONTENTS

Chapter I. Audit Requirements

Section:	<u>Page</u>
A. Purpose and Applicability-----	I-1
B. Personnel Qualifications-----	I-1
C. Organization and Financial Control-----	I-3
1. Cash-----	I-3
2. Payroll-----	I-3
3. Procurement-----	I-4
D. Records and Files-----	I-4
1. Federal Cost-----	I-4
2. In-Kind Contribution-----	I-5

Chapter II. An Accounting System for BWP Sponsors, CEP Contractors and CAA's

A. Purpose of this Chapter-----	II-1
B. Accounting Concepts to be Followed by BWP Sponsors, CEP Contractors and CAA's-----	II-2
C. Accounts of the Sponsor-----	II-4
D. Internal Control-----	II-5
E. Timeliness in Recordkeeping-----	II-6
F. Required Reports-----	II-6
G. Maintenance of Double-Entry Accounting System, Journals To Be Maintained and Sample Accounting Entries-----	II-6
1. General-----	II-6
2. Payroll Journals-----	II-7
3. Check Disbursement Journal-----	II-9
4. Petty Cash Register-----	II-11
5. General Journal-----	II-13
6. General Ledger-----	II-13
7. Sample Accounting Entries-----	II-14
H. Support Data Required for Cost Accounts-----	II-17
I. Chart of Accounts--Accounts and Definitions---	II-22
1. Chart of Accounts-----	II-22
2. Account Definitions-----	II-25
J. Accounting Procedure Guidelines-----	II-42
K. Closing of Books-----	II-50
L. Reporting Requirements-----	II-52

Chapter III. Physical and Financial Control of Personal Property

A. Policy and Purpose of Issuance-----	III-1
B. Personal Property Defined-----	III-2
C. Maintenance Procedures and Organizational Re- sponsibilities-----	III-3
D. Suggested Classification of Groupings-----	III-11

Appendix A

CHAPTER I

AUDIT REQUIREMENTS FOR FINANCIAL CONTROL

A. PURPOSE AND APPLICABILITY

1. This chapter states BWP's minimum requirements for the control of and accounting for its funds. BWP program evaluations and audits will include a review of the financial controls and accounting systems (secs. C and D) to ascertain each sponsor's and subsponsor's compliance.
2. The principles and accounting standards indicated for the NYC program shall be applicable for all new programs, which are administered through BWP, i.e., Operation Mainstream (Title II -205-d), New Careers (Title II-205-e), Special Impact Program (Title I-D), Work Experience Program (Title V), and Concentrated Employment Programs. This accounting manual shall also apply to the Community Action Programs.
3. The proper use of the accounting manual will meet the requirements of section C and D. However, the manual is not prescribed. Any accounting system which meets section C and D requirements will be acceptable to BWP.

B. PERSONNEL QUALIFICATIONS

1. The accounting transactions and records must be maintained under the direct supervision of a qualified accountant or an accounting service. Bookkeeping service, subject to a review by a qualified public accountant, is acceptable where the size of the organization does not justify staffing up for this function within the organizational structure of the agreement. Care should be exercised in determining the extent of accounting service required consistent with the number of prior transactions involved.

The degree of qualification will bear a direct relationship to the size of the organization, considering of course, the complexity of the BWP Programs.

2. The degree of qualification will be commensurate with the size of the sponsor, the amount of BWP financing, and the complexity of the sponsor's program. A sponsor having a multimillion dollar program should have an accountant whose qualifications are those that would be required by an industrial corporation of comparable size. For the largest sponsors, the accounting head should have a degree in business administration from an accredited university; have at least 10 years of experience as a controller or head of a major accounting group within the accounting department of an industrial or financial organization, government, or nonprofit institution. These requirements will be scaled down for smaller organizations to the minimum requirement. The minimum requirement for the smallest BWP sponsor will be that the head of the accounting department be an experienced bookkeeper capable of maintaining a complete set of accounts and supporting records and files, drawing off a trial balance, preparing financial statements, and maintaining payroll records including the required returns to the Federal and State Governments.
3. A sponsor may elect to have accounting provided by a public accountant or bookkeeping service organization. The Department of Labor will require a degree of proficiency of the head of such an organization comparable to that required of a sponsor's accounting head.
4. In some instances, a combination of these two approaches may be desirable. For example, payroll operations and detailed cost accounts may be performed by a bookkeeping service organization, with the sponsor maintaining accounting capability for the purpose of setting fiscal policies, preparing consolidated reports, and preparation of program cost estimates. In this situation, the Department of Labor will require that the sponsor's accounting head and the bookkeeping service organization have the prescribed qualifications.
5. The General Provision of the agreement, clause number 32, titled "Accountant" indicates that when the Secretary so requires, the sponsor shall retain the services of an independent certified public accountant or independent licensed public accountant, certified or licensed by a governmental regulatory authority, to perform such audits and submit such reports as the Secretary may require.

C. ORGANIZATION AND FINANCIAL CONTROL

1. CASH

- a. BWP funds shall be deposited in a SEPARATE bank account, unless this requirement has been waived, in writing, by the Director of the Bureau of Work Programs. Signature cards of persons authorized to sign checks should be filed with the designated project officer. All disbursements shall be made by check. Blank checks shall not be available to the procurement and accounting staff. The use of check writing equipment is encouraged. It should be kept under lock so that only authorized signatories have access to the machine. Countersignatures to checks are not required but do provide an excellent additional safeguard. The person authorized to sign checks shall not have access to either the procurement process or the accounts.
- b. Bank statements must be received at least monthly and shall be mailed by the bank directly to the accounting department. The person signing the checks shall not have access to the statement. The accounting department must reconcile the bank statement.
- c. Each check issued to employees, enrollees, suppliers or subcontractors must be supported by APPROPRIATE DOCUMENTATION, such as a purchase order and receiving report, payroll voucher and time and attendance report, subcontractors invoice, or petty cash voucher. Such documents must be inspected and approved by the person signing the check prior to the check's being signed.

2. PAYROLL

- a. Enrollee and staff appointments must be documented by enrollment or appointment forms. The enrollment process must be performed independently of the enrollee and staff supervisor. Staff salaries must relate to established job descriptions and salary structure. Time reports must be signed by each enrollee and staff member at the conclusion of the payroll period and countersigned by the supervisor.

- b. Payroll preparation must be completely SEGREGATED from the disbursement function. Payroll checks must not be routed into the payroll organization but must be delivered directly to program offices and job centers. Frequently the distribution of salary checks by supervisors cannot be avoided. Such distribution eliminates the control obtained by the segregation of time reports and check distribution. This can be minimized by the periodic distribution of salary checks and identification of recipients by the sponsor's staff which has no responsibility for payroll or check preparation.
- c. It is recognized that these elements of control cannot be attained by smaller sponsors. In such instances, it shall be the responsibility of the project director or the chief accounting official to personally determine that salary checks are properly computed and issued to bona fide staff and enrollees.

3. PROCUREMENT

- a. The procurement of equipment, supplies, space, transportation, and any other items must be the result of an arms-length relationship between the sponsor and the vendor. All procurement must be supported by purchase orders, receiving reports, and vendor invoices. This requirement is waived in the instances of utility and petty cash purchases. In these latter two instances, vendor invoices or cash register receipts will support procurement.
- b. All procurement must be for the benefit of the Bureau of Work Programs. A designated official of the sponsor must sign each invoice or petty cash voucher, thereby indicating that the procurement is for such purpose.

D. RECORDS AND FILES

1. FEDERAL COST

- a. Accounts. - The operating cost account structure must be susceptible of identification to each line item appearing in the budget which is part of the BWP agreement. Reports to the Department of Labor shall be prepared from such accounts. Accounts may be maintained on the basis of checks (cash basis), or accrued cost at the option of the sponsor. Reports on Form BWP-25 shall indicate cash or accrual basis.
- b. Cash. - Cash accounts must be supported by a copy of the bank statement, and bank reconciliation and file of cancelled checks maintained in numerical order by the month of bank clearance.

- c. Payroll.- Payroll accounts must be supported by the payroll voucher and pay computation schedules, the appointment records, and time reports. Forms 941, W-2, and State tax reports must also support the payroll accounts including fringe benefit charges.
- d. Procurement.- As noted above, procurement accounts must be supported by a copy of the purchase order, vendor invoice, and receiving report where appropriate. The designated officer must indicate his acceptance of the charges and the accuracy of the price by signature on the invoice. Procurement of rent, insurance, and other service which is subject to agreement must be supported by copies of lease or service agreements and insurance policies. Sponsors having a large number of such types of expenses should maintain subsidiary registers of rent, insurance, etc., to facilitate the orderly management of such procurement.

2. IN-KIND CONTRIBUTION

- a. The sponsor's in-kind contribution must be supported by a formal set of accounts maintained for each budget line item as contained in the contract. These accounts must be SUPPORTED BY DOCUMENTATION comparable to that required for Federal costs. In those cases where the in-kind contribution consists of allocations of sponsor's expenses incurred for other facets of his operation, the allocation must be supported by a narrative justification and computation. Cost distributions must be substantiated by detailed gross cost of salaries, buildings, transportation, supplies, utilities, or other in-kind cost as contributed by the sponsor.
- b. The types of costs acceptable as in-kind are specified in BWP regulations (title 29, CFR, par. 50.1).

3. DISPOSITION OF ACCOUNTING RECORDS

- a. The sponsor shall preserve and make available for inspection and audit his records (1) until the expiration of 3 years from the date of the final payment, and (2) for such longer period, if required by applicable statutes.
- b. Except for records which may be related to "Disputes" as indicated in the "General Provisions" of the agreement the sponsor may, after 2 years, fulfill his obligation to retain his record by substituting photographs, microphotographs, or other authentic reproduction of such records.

- c. If the sponsor goes out of business, he shall contact the contracting officer and indicate where the records will be located for auditing purposes. Based on the instructions of the contracting officer, the sponsor may be allowed to send his records to the Department of Labor for audit and storage.

CHAPTER II

AN ACCOUNTING SYSTEM FOR BWP SPONSORS

A. PURPOSE OF THIS CHAPTER

1. This chapter is to be used by all BWP sponsors, either as the sponsor's official accounting system or as a guide in the sponsor's development of a system. The chapter provides:
 - a. A uniform system of accounts;
 - b. Procedures for maintaining and recording BWP costs and revenue, and other financial transactions; and,
 - c. A means for developing and maintaining financial and statistical data required
 - (1) to support sponsor's invoices, and
 - (2) to prepare cost reports for BWP and sponsor management.

2. The essentials of a sound and effective accounting system lie in its
 - a. simplicity,
 - b. availability of data,
 - c. flexibility,
 - d. ability to relate cost data to other facets of the BWP operation, and
 - e. auditability.

These factors have all been taken into consideration in the development of the system.

3. The limitations in the accounting flexibility of many sponsors resulting from their tie-in with "umbrella-type" organizations or their character as city and State government agencies and boards of education have been considered. Such sponsors must frequently accept the accounting systems imposed by State or

local governments or other agencies and boards. Recognizing these account limitations imposed on many sponsors, and the varied sizes of BWP projects, no attempt is made to provide detailed instruction in all aspects of the financial operations of the sponsors. Indeed, the accounting principles are sufficiently broad to cover each sponsor's situation. No compromise, however, in the accounting principles under which the sponsor must operate will be permitted.

This handbook should be used by Concentrated Employment Program contractors as a guide to the development and maintenance of accounting systems necessary to the control of funds available under the CEP contracts and/or agreements. Since the CEP program includes a combination of MDTA, Special Impact, NYC, and New Careers components, it has been necessary to utilize the definitions and instructions contained in this handbook for the Bureau of Work Programs. Further information may be obtained from the "CEP Instructions on Invoicing, Reporting Costs, and Accounting." It should be noted that the Detail Statement of Costs for the CEP Program is Form MA-Temp-739. However, this form is similar to the Form BWP-25 which is referenced in this manual.

4. Even though this manual is primarily designed for BWP sponsors operating under agreements, this accounting system may be followed by the Community Action Agencies. The flexible guidelines for fiscal accountability does not impose a rigid system upon CAA's. Thus, any type of accounting system complying with the principles and standards outlined in this manual shall be considered acceptable.

B. ACCOUNTING CONCEPTS TO BE FOLLOWED BY BWP SPONSORS

1. Accounting System

- a. While the ideal accounting system is an accrual system of accounts, we have accepted the fact that the sponsors, frequently bound by a prescribed accounting system, cannot be held to a full accrual system of accounts. This issuance prescribes a cash system of accounts; however, it encourages consideration of the adoption of an accrual system of accounting, especially with respect to enrollee wages and staff salaries. Not only does this approach provide better management controls over the operation by the sponsor, it also provides the BWP program officials a more realistic means of relating statistical data, including enrollee hours, to actual costs incurred.

- b. A definition of accrual accounting is as follows:

Accrual Basis of Accounting -- The basis of accounting in which the effects of a transaction are recognized at the time the transaction takes place regardless of when payment or collection is made. Under this basis, revenue is recognized and recorded during the period when it is earned whether or not it has been received, and expense (or cost), is recorded during the period when it is incurred whether or not payment has been made. Generally, the accrual basis of accounting gives meaning to monthly cost figures as they relate to actual performance under an agreement.

- c. Where the local system provides for an accrual (or modified accrual) system of accounting, the sponsor will follow such system, so advising the Contract Services Division, Office of Financial and Management Services, U. S. Department of Labor, by a notation on the monthly Detailed Statement of Costs.

2. Cost Accounts

- a. Costs, as defined in this chapter incorporated all 1600 series of accounts as set out in section V. The procurement of equipment (including related freight cost), is treated as an expense for the purpose of accounting for contract costs. This complicates the problem of establishing accounting controls over personal property records. Personal property records are spelled out in Chapter III "Physical and Financial Control of Personal Property." In order to establish management control over property, the cost of property, as defined in that chapter will be recorded in account 1201, Furniture, Fixtures, and Equipment. The contra to this account will be account 1202, Furniture, Fixtures, and Equipment - Contra credit account or account 1430 - Department of Labor - Property. The latter accounts will at all times be credits. The debit entry will be in agreement with the total of the costs recorded on the property equipment cards.
- b. It is essential that the arrangement of all incurred costs for report purposes to BWP be maintained in the set group of expense accounts, disregarding the normal accounting treatment of such expenditures.
- c. Certain of the costs incurred may require allocation of two or more accounts. An example is staff salaries. It is entirely possible that an individual will devote his energies to more

than one facet of the operation. In order to minimize the allocation, which at best is an estimate, we have established the rule that where an individual is devoting 90 percent or more of his time to a particular phase of the operation, his entire salary will be charged to that account.

3. Bank Reconciliations

Bank reconciliations must be performed at the end of each month of operation. While the principles of check reconciliation are generally understood and should not require an explanation, the following simplified approach is set out.

Checkbook Balance Equals

Bank Balance (end of month) per bank statement.

Less: Checks written by the sponsor which did not clear the bank.

Add: Deposits by sponsor which are not on bank statement. Differences which might be disclosed as a result of this reconciliation are (1) bank charges which must be entered on the check register and (2) a possible error in totaling the checkbook.

C. ACCOUNTS OF THE SPONSOR

1. Accounts of the sponsor, relative to his contribution to the program must be maintained separately including checking accounts, cost accounts, and asset and liability accounts. The cost concepts set out here for the maintenance of accounts, relative to costs chargeable to the BWP, apply equally to the records applicable to costs chargeable to sponsors. In order to maintain accuracy in separation costs, it is necessary that the sponsor adopt separate records for each program area (NYC, Special Impact, Community Employment and Betterment Program, New Careers, Title II and MDTA Programs) in all respects including journal vouchers, general ledgers, and paid and unpaid voucher files.
2. In-kind contributions by the sponsor should be recorded in the month the service or property is provided. Thus, if the sponsor has agreed to provide rent, valued at \$400 per month, the following entry will be recorded in the books of the sponsor.

Debit: Rent	\$400
Credit: Contribution by sponsor	\$400

3. This entry will only be made where the building is (a) either owned by the sponsor or (b) where another agency provides space

to a sponsor at no cost. The principle of the entry is that where recording in-kind costs, the sponsor (a) will prorate the cost over the life of the asset contributed and (b) record all contract entries as "Contributions by Sponsor." If it is desired to record the in-kind asset in total at the outset of the program, an entry will be made in a deferred charge account, at the same time, crediting "Contributions by Sponsor." The actual application of the in-kind contribution to the project will be recorded at the end of each month by credit to the deferred charge account. The accounting entries would be:

Debit: Reserve for deferred project equipment\$4,800
Credit: Contribution by sponsor\$4,800
Estimated value of equipment supplied by
the sponsor for 26 weeks.

Debit: Use of project equipment\$600
Credit: Reserve for deferred project equipment\$600
Equipment used in September.

D. INTERNAL CONTROLS

1. Internal controls, essential to a soundly managed organization, apply to both large or small operations. In most instances, common sense dictates the procedures that should be followed in avoiding conditions that can lead to possible theft or fraudulent records. The following are minimum safeguards which should be followed to the extent possible, considering, of course, the size of the organization:
 - a. The person handling funds, including checks, should not have access to either the journals or ledgers.
 - b. Payroll checks should never be returned to the payroll clerk who maintains the payroll journals and receives the time cards. Distribution of such checks should be the responsibility of a person not in any way associated with the payroll desk.
 - c. Petty cash vouchers should be approved by a person other than the petty cash clerk. Petty cash expenditures should cover minor expenditures only and never serve as a substitute for the issuance of checks.
 - d. Physical inventories should be taken by a person or persons not responsible for, nor having access to, the inventory records.

2. These are but a few of the precepts of internal control which should be followed. The general principle, of course, is that those handling funds or assets should never be in a position to change accounting records.
3. Large sponsors should staff their organizations with internal auditors who will be responsible to management for auditing subcontractors and delegate agencies' records to assure that accounting policies and procedures are followed in accordance with sub-agreements.

E. TIMELINESS IN RECORDKEEPING

Timeliness in recordkeeping is essential if reports are to be maintained on a current basis. This is a "must" since BWP requires the submission of up-to-date reports each and every month. The scope of the BWP operation is such that this requirement can easily be met. Delays in recording journal entries, paying bills as they become due, and submitting reports can be costly and lead to errors in the maintenance of the books of accounts.

F. REQUIRED REPORTS

Fiscal reports required under the terms of the agreement must be in accordance with schedules as set out in Administrative Notice No. 3-66 (see sec. L of this chapter). These data are used in the development of analytical reports. All sponsors must cooperate to facilitate the development of data useful to management, the Bureau of the Budget, and the Congress. There will be no exception granted in meeting the report deadlines set out in section L. Compliance with the format of records and transactions in this chapter will expedite the preparation of the required reports and assure the validity of the submitted data.

G. MAINTENANCE OF DOUBLE-ENTRY ACCOUNTING SYSTEM, JOURNALS TO BE MAINTAINED, AND SAMPLE ACCOUNTING ENTRIES

1. General

- a. All BWP sponsors must maintain double-entry system of accounting. These records may be prepared manually, on bookkeeping machines, or on mechanized computer equipment.
- b. All accounting transactions must initially be recorded in a journal as a double entry. This part of the section spells out the various journal records to be maintained. The average size project can operate with a payroll journal, check disbursement journal, a petty cash register, a general journal, and a general ledger. These accounting records are discussed below.

2. Payroll Journals

- a. The source of entries in the payroll journals will be the payroll vouchers. The payroll vouchers contain summary totals of labor service by cost account category, the tax liabilities charged to the employee, and the net amounts of funds due the employees. The summary totals are derived from a payroll schedule or listing, which shows each employee's name, his gross pay, tax and other deductions, and net pay. The schedule also contains the check number of the checks drawn for each employee. A payroll checking account will be replenished from the regular checking account to cover the net amount of funds due employees on each payroll voucher. As an initial action, a nominal amount of funds, based on minimum banking requirements, will be transferred from the regular checking account to the payroll checking account. A sample of the payroll journal follows.

- b. The maintenance of an accrual system of recording wages will not disturb the procedures set out with respect to recording payroll vouchers in the payroll journal. This manual proposes the establishment of month-end accrual, to be reversed on the first day of the following month. An example of this entry is set out as item j and k of paragraph G7 below.

3. Check Disbursement Journal

- a. Separate journals will be prepared each month. The check disbursement journal will contain all checks written out of the regular checking account. In addition, bank charges applicable to the regular checking account will be recorded in this journal. Since no insistence is made to establish an accrual system of maintaining the records, expenses under the cash system of accounting will be recorded (other than payroll) at the time of payment. Should a sponsor desire to maintain his records on an accrual basis, the accrual can be recorded in the general journal or a voucher payable journal. In the latter case, all payments, relative to costs recorded in the voucher payable journal, would be a charge to an accounts payable account in the check disbursement journal. The entry in the general journal would be in the nature of a month-end accrual, to be reversed on the first day of the succeeding month. A sample format of a check disbursement journal is set out below.

- b. There are some complexities to recording the payment to the Internal Revenue in the check disbursement journal where Federal Reserve deposits have been made. The journal entry would be as follows:

Debit:

Federal withholding taxes payable\$450.00
Social security taxes payable 675.00

Credit:

Federal Reserve deposits\$750.00
Cash in bank - Regular account 375.00

In this case, the deposits to the Federal Reserve System have the same effect as a certified check in meeting the obligation to the Federal Government. In order to use the Federal Reserve deposit column in the check disbursement journal, both for payments to the system and as credits when applying the payment to the liability of the sponsor to the Federal Government, the following rule must be applied:

- (1) Payments to Federal Reserve bank will be a debit to the account.
 - (2) Application of the payment is treated as a credit. This will be reflected on the check disbursement journal by bracketing $\left[\right]$ the amount credited in the Federal Reserve bank deposit account.
- c. The replenishment of the petty cash fund will be processed as a one-check entry, charging all of the accounts making up the cash payments out of the fund. Item i in paragraph G7 below typifies the petty cash replenishment transaction.

4. Petty Cash Register

The petty cash register will not serve as a posting media to the general ledger, but rather as support for the check in the check disbursement journal. Each month, or more frequently, if necessary, the payouts will be listed by account. When the fund is in need of replenishment, the payment data will be totaled and crossfooted. That balance will equal the petty cash check. An example of a petty cash register is set out below:

5. General Journal

- a. The general journal will include entries not included in the payroll journal, the check disbursement journal or the petty cash register. Included in this journal will be recorded receipts and accruals. An example of the latter entry would be the following:

Debit: Employer's cost of fringe benefits - FICA ...\$72.50
Credit: Social security taxes payable (explain transaction)..\$72.50

- b. Each individual general journal entry will be posted separately to the general ledger, rather than by summary action as is the case with the check disbursement journal.
- c. The frequency of recording fringe benefits accrued is a matter best determined by the accountant for the sponsor. Generally speaking, the entry should immediately follow the payment of the payroll to the enrollees or staff of the sponsor.
- d. If an accrual system of accounting is adopted, the use of the general journal will increase, unless a voucher payable journal is used.

6. General Ledger

- a. The general ledger will include both control and detail accounts as indicated in section 1 of this chapter.
- b. Postings to the general ledger will be monthly from the payroll and check disbursement journal. Postings from the general journal should be daily. A check mark should be made next to the posting amount in the journals whenever recording the amount into the general ledger.
- c. The account numbers, identifying the general ledger control and detail accounts are only suggested and need not be followed by the sponsor. These numbers have been printed on the cost (invoice) sheets for the purpose of machining this detail into the budget and cost system of BWP.
- d. At the end of each month, prior to the preparation of the cost report, the general ledger must be proved and reviewed in the following manner:

- (1) the detail accounts must be in agreement with the related control accounts;
- (2) the general ledger accounts must be self balancing (credits equal debits);
- (3) unreasonable balances or amounts should be analyzed and necessary adjustments, if any, made prior to the preparation of monthly reports.

7. Sample Accounting Entries

To further emphasize the double-entry system of accounting and the various journals, a series of journal entries, likely to be found in the books of a BWP sponsor are set out below. These entries refer to the journals which have been described in this chapter. (A chart of accounts is set out in sec. I detailing, by account description, the minimum account requirements of a sponsor's set of books.)

a. Billing BWP for an Advance -- General Journal

Debit: Accounts receivable\$10,000.00
 Credit: Contribution from BWP\$10,000.00
 To record a request for advances at the beginning of the project or at any time during the life of the project.

b. Receipt of Funds from BWP -- General Journal

Debit: Cash in bank -- BWP funds\$10,000.00
 Credit: Accounts receivable\$10,000.00
 To record the receipt and deposit of funds from BWP -- based on previous billing.

c. Receipt of Department of Labor Furnished Property - General Journal

Debit: Furniture, fixtures and equipment.....\$25,000.00
 Credit: Department of Labor - Property\$25,000.00
 To record the receipt of excess property furnished by the Department of Labor.

d. Recording of Payroll Voucher -- Payroll Journal

Debit: Payroll (Gross and by category of payroll .. \$2,000.00

Credit:

Federal withholding taxes payable\$ 150.00
Social security taxes payable 72.50
States taxes payable 100.00
(Other employee deductions) 100.00
Cash in bank -- Payroll account1,577.50
To record payment of payroll voucher, recording
payroll gross and in detail, establishing the tax
liability, and other liability deductions from the
employees' pay.

e. Replenishment of Cash in Bank -- Payroll Account -- Check
Disbursement Journal

Debit: Cash in bank -- Payroll account \$1,577.50
Credit: Cash in bank -- Regular account 1,577.50
To transfer to the payroll cash account an amount equal
to the total payroll checks disbursed.

f. Recording of Employer's Share of Fringe Benefits Costs --
General Journal

Debit:

Employer cost of fringe benefits -- enrollee
expenses -- FICA \$72.50
Employer cost of fringe benefits -- staff --
FICA 15.00

Credit:

Social security taxes payable 87.50
To record the employer's portion of social security taxes
in accordance with Federal regulations.

g. Recording the Monthly Deposit with the Federal Reserve Bank --
Check Disbursement Journal

Debit: FRB deposits\$375.00
Credit: Cash in bank -- Regular account 375.00
To record the deposits with the Federal Reserve Bank,
required for the first two months of a quarter. The
deposit will include (1) withholding taxes of enrollees
and staff, (2) social security taxes withheld and (3)
the contribution of the employer's share of social
security taxes.

h. Establishing Petty Cash Fund -- Check Disbursement Journal

Debit: Petty cash fund \$300.00
Credit: Cash in bank -- Regular account 300.00
To record initial establishment of petty cash fund.

i. Replenishment of Petty Cash Fund -- Check Disbursement Journal

Debit:

Enrollee transportation..... \$50.00
Staff salary expenses - Transportation. 30.00
Expendable office supplies 10.00
Custodial service and supplies 20.00

Credit: Cash in bank -- regular account 110.00
To replenish the petty cash fund based on vouchers
evidencing charges against the fund.

j. Recording of Payroll Month-End Accrual -- General Journal

Debit:

Enrollee wages \$4,400.00
Staff salaries (distributed cost) 800.00

Credit: Month-end accruals 5,200.00
To record 10/14th of the gross payroll which covers the
period February 18 to March 4, 1966.

OR

Debit:

Enrollee wages \$5,000.00
Staff salaries (distributed cost) ... 1,000.00

Credit: Month-end accruals 6,000.00
To record the gross payroll which covered the period
February 14 to February 28, 1966.

k. Reversal of Payroll Month-End Accrual -- General Journal

Debit: Month-end accruals \$5,200.00

Credit:

Enrollee wages 4,400.00
Staff salaries (distributed cost) 800.00
To reverse (on first day of succeeding month) the payroll
accrual recorded in j above. (Same entry for second part
of j above.)

1. Payment of Supportive Costs -- Check Disbursement Journal

Debit: Office equipment - Purchase	\$250.00
Office equipment - Rental or use	75.00
Project equipment - Purchase	100.00
Project equipment - Rental or use	45.00
Rent	250.00
Expendable office supplies	40.00
Communications	50.00
Utility costs	35.00
Custodial services and supplies	85.00
Other direct costs	40.00
Credit: Cash in bank -- Regular account	970.00

To record payments on costs chargeable to BWP funds.

H. SUPPORT DATA REQUIRED FOR COST ACCOUNTS

All evidences of cost must be supported by documentation relative to the category of cost incurred. Support and justification of such cost will be evidenced by:

1. Enrollees' Payrolls

Time and attendance reports on all enrollees properly signed by a supervisor. Further, there must be documentation of the fact that each enrollee meets the conditions of employment as spelled out in the contract. Violations of these contractual conditions will be the basis for charge-backs against the sponsors. With respect to time and attendance reports, the actual hours worked must be reported.

2. Staff Salaries

Time and attendance reports are required for all staff salaries with the exception of the project director and his top staff including but not limited to the legal counsel, controller, and assistant project director. The salaries and positions must be in agreement with the conditions of the contract. Variations to these conditions may exist where the sponsor has established different employment conditions and policies.

3. Federal and State Tax Expense

The necessary tax forms including Federal Form 941 and State and city tax reports must be available and supported by payroll records maintained in connection with (1) and (2) above. Taxes must be paid on a current basis and be filed in accordance with local, State, and Federal regulations. When the costs of fringe benefits are paid to a local government as part of a flat percentage of gross payroll, the percentage must be agreed to as part of the contract. These conditions will exist when the staff employees of a sponsor are, in fact, city employees on loan to the sponsoring organization.

4. Staff Travel Expenses

Transportation costs and per diem expenses must, in all instances, be supported by evidences of such expense, properly approved by a responsible official authorized to approve such expenditure.

5. Office and Project Equipment

Prior to the procurement of equipment, there must be evidence that an attempt was made to secure the equipment through Government excess or surplus. Correspondence relating to such an attempt must be on file for ready reference by the auditors.

a. Rental - An agreement, signed by both the sponsor and the rental organization must be on file in support of any rent agreement. The agreement must state:

- (1) the monthly cost of the rental,
- (2) the length of time of the agreement, and
- (3) any other conditions of rental including purchase options, damage clauses or time extensions.

b. Purchase - Procurement of major items of equipment (see "Chapter 3210 - Property Handbook for Contractors" for definition) requires prior approval from the Department of Labor. Details of these approvals are spelled out in the project proposal materials. All paid invoices must show, on their face:

- (1) date paid,
- (2) check number,
- (3) account to which charged,
- (4) evidence of receipt,
- (5) signature of person recording such information.

6. Rent

Rental agreements must be on file, signed by both the sponsor and the owner or agent of the property. The conditions of the rental agreement must be detailed in the rental contract including:

- a. monthly cost;
- b. length of the lease;
- c. rate per square foot (if computed on this basis);
- d. services considered part of the lease including heat, light and power, custodial service, maintenance and repair provision and communications;
- e. tax escalation clauses; and
- f. any other conditions considered a part of the rental agreement.

7. Insurance and Bonding

Insurance and bonding agreements must be on file, in support of such recorded costs. Where coverage is carried by an "umbrella" agency or a municipal government, a statement including such coverage and the extent of the coverage must be available for review by the auditors.

8. Expendable Office Supplies

Paid invoices, supported by evidence of delivery must be on file in support of such costs. All paid invoices must be stamped to show:

- a. date paid,
- b. check number,
- c. the account to which charged, and
- d. the signature of the person recording such information.

9. Communication and Utility Costs

Copies of paid bills, noted as:

- a. date paid,
- b. check number,
- c. account charged, and
- d. signature of person recording payment data, must be on hand for audit purposes.

Should such costs be part of the rental of premises, the rental agreements must clearly identify the nature and extent thereof. If these charges are based on allocations, there must be a statement on hand indicating the basis for the allocation. Further, there must be evidence that the project director is in accord with the allocation base.

10. Custodial Services and Supplies

Casual janitorial service need not be under contractual agreement; however, where the individual or individuals performing custodial services are on a contract, a copy of the contract must be available and be properly signed. The purchases of custodial supplies must be evidenced by a delivery slip and signed invoice, noted as to:

- a. date paid,
- b. check number,
- c. account to which charged, and
- d. the signature of the person recording the payment.

This category of expenses excludes janitors on the staff of the sponsor. If these charges are based on allocations, there must be a statement on hand indicating the basis for the allocation. Further, there must be evidence that the project director is in accord with the allocation base.

11. Other Direct Costs

All project costs, other than those enumerated above and subagreement costs will be recorded as other direct costs. As noted above, all such costs must contain evidences of delivery and properly noted as to:

- a. date paid,
- b. check number,
- c. account charged, and
- d. signature of person recording payment data.

12. Sub-sponsor Accruals and Payments

- a. This area of operation requires special attention of the BWP sponsors. Controls must be instituted to assure:

- (1) services have been rendered to support this billing,
 - (2) the sub-sponsor has placed into training by occupation, these agreed to in the subagreement,
 - (3) the job coordinator of the prime sponsor has verified the billing document that the funds are a proper charge, and
 - (4) the services have not been paid in a previous billing.
- b. The prime sponsor has the responsibility to develop accrual techniques so that current reports properly reflect the costs of all services rendered to the sub-sponsors. A proposed format for maintaining accrual controls over sub-sponsors is set forth in this manual.
- c. Paid sub-sponsor billing documents must be filed to serve as a ready reference of such activity for the auditors.

I. CHARTS OF ACCOUNTS - ACCOUNTS AND DEFINITIONS

1. In order to implement the accounting system described, the following chart of accounts is suggested:

BWP Funded Records

Major Account Grouping	<u>Account Control No.</u>	<u>Detail No.</u>
Current Assets	1000	
Cash in bank - Regular account		1010
Cash in bank - Payroll account		1020
Accounts receivable - BWP		1030
Petty cash fund		1040
Deferred Charges	1100	
Deposits with Federal Reserve bank		1110
Subagreement contra account		1150
Fixed Assets	1200	
Furniture, fixtures, and equipment		1201
Furniture, fixtures, and equipment - contra credit account		1202
Current Liabilities	1300	
Federal withholding taxes payable		1310
Social security taxes payable		1320
State withholding taxes payable		1330
State unemployment taxes payable		1340
State retirement tax payable		1350
Loans payable		1360
Accounts payable <u>1/</u>		1370
Month-end accruals <u>1/</u>		1380
Subsponsor payable		1390
Equity	1400	
Contribution by BWP - Fund		1410
Current year cost chargeable to BWP <u>2/</u>		1420
Department of Labor-Property		1430

Current Operating Costs

1. Enrollee expenses	1600	
Enrollee wages for work		1601
Enrollee wages for other participation		1602
Employer's cost of fringe benefits	1610	
FICA		1611
Workmen's Compensation		1612
Other		1613
Other direct enrollee costs	1620	
Enrollee transportation		1621
Other supportive services		1622
Stipends		1624
2. Administrative and staff services costs		
Salaries and wages	1630	
Project administration		1631
Recruitment		1632
Counseling services		1633
Supervision		1634
Remedial education		1635
Job development, placement, referral, and followup		1636
Other services supplied by staff		1637
Orientation		1638
Employer cost of fringe benefits	1640	
FICA		1641
Workmen's Compensation		1642
Other		1643
Staff travel expenses	1650	
Transportation		1651
Per Diem		1652
3. Operational costs		
Supportive costs	1660	
Office equipment - purchased		1661
Project equipment - purchased		1662
Rent		1663
Insurance and bonding		1664
Office equipment - rental or use		1665
Project equipment - rental or use		1666
Training costs		1667
Other direct costs	1670	
Expendable office supplies		1671
Communications		1672
Utility costs		1673
Custodial services and supplies		1674
General		1675

4. Undistributed (indirect) costs	1680
5. Subagreement costs	1690

1/ When sponsor is on an accrual or modified accrual system.

2/ Based on closing of cost accounts at end of contract
(differences between 1410 and 1420 represent funds to be
returned to or due to BWP.)

2. Account Definitions

Cash in Bank--Regular Account
Account 1010

Debit this account for all deposits and returned checks other than payroll checks. This entry will be supported by deposit slips and schedules of cancelled checks. In the latter instance, the cancelled checks must be attached to the schedule as support for the entry.

Credit this account for all disbursements as recorded on the monthly check disbursement journal. This latter entry will include bank charges in addition to checks issued during the month.

Balance as of the end of each month must be reconcilable to the bank statement and will reflect the funds available as of that date.

Cash in Bank--Payroll Account
Account 1020

Debit this account for (a) the initial deposit to this account, not to exceed the limited deposit requirements of the local bank, and (b) the replenished check out of the cash in bank, regular account covering the net amount of each payroll voucher (net of any cancelled checks). Also debit this account for all returned payroll checks issued in error.

Credit this account for the net amount of all payroll checks as supported by the payroll vouchers.

Balance will at all times be in agreement with the permanent funding of this account per (a) above under debit.

Accounts Receivable--BWP
Account 1030

Debit this account with the net amount of invoices submitted to BWP. (The contra entry will be contribution by BWP--Account 1410).

Credit this account with (a) receipts from BWP based on invoice submission and (b) any downward adjustment of such invoices as determined by BWP. (The contra entry will be contribution by BWP).

Balance at the end of any month will be in agreement with all pending invoices being processed by the Department of Labor.

Petty Cash Fund
Account 1040

Debit this account in the amount of the funds initially establishing this account.

Credit this account only when it is determined that the established balance is to be reduced, and eliminated following the termination of the contract.

Balance of this account will not be effected by payout or reimbursible activity. Such payouts and related costs will be recorded in the regular checking account when reimbursing the fund.

Deposits With Federal Reserve Bank
Account 1110

Debit this account for the amount of deposits with the Federal Reserve bank. (Deposits are required when monthly payroll deductions including Federal withholding and employees social security deductions equal \$100 or more.) Payments cover the first 2 months of a calendar quarter. Deposits must be made once a month not later than the 15th of the month following.

Credit this account when applying the deposits to the quarterly submission of payroll taxes to the Director of Internal Revenue.

Balance in this account reflects the unapplied deposits with the Federal Reserve bank. At no time will this account contain the deposits of more than 2 months' activities.

Subagreement Contra Account
Account 1150

Debit this account when the subsponsor submits an invoice to the prime sponsor. This amount will be the total amount of the invoice.

Credit this account when the subsponsor submits a cost statement for the actual cost incurred.

Balance in this account reflects the total unliquidated advances to all subsponsors.

Furniture, Fixtures, and Equipment

Account 1201

Debit this account concurrent with the recording of property on the property record cards as defined in this chapter "Physical and Financial Control of Personal Property." Transactions in this account will be recorded in summary and will include equipment purchased, both new and used, by the contractor with Federal funds or excess property furnished by the Department of Labor. Freight costs, considered a part of the asset cost, will also be recorded in this account.

Credit this account when disposing of assets either by transfer to the Federal Government or any other disposition action.

Balance in this account, will at all times, agree with the summary of the total costs as reflected on the individual property record cards.

Furniture, Fixtures, and Equipment - Contra Credit Account
Account 1202

Credit this account as a contra to all debit entries for property purchased in Account 1201 - furniture, fixtures, and equipment.

Debit this account as a contra to credit entries for property purchased in Account 1201.

Balance at all times will be a credit and in exact agreement with the balance of property purchased in Account 1201 - furniture, fixtures, and equipment.

Federal Withholding Taxes Payable
Account 1310

Credit this account when recording the payment of payroll vouchers. This amount represents the Federal withholding taxes of individuals on the payroll.

Debit this account when recording the quarterly tax payment to the Director of Internal Revenue. Also debit this account when recording downward adjustments of payroll vouchers, generally accompanied with the cancelled checks of the individuals.

Balance represents the amount due Internal Revenue, disregarding unapplied deposits with the Federal Reserve bank. At no time should this balance exceed the activity of a full calendar quarter of deductions.

Social Security Taxes Payable
Account 1320

Credit this account when (a) recording the payment of payroll vouchers and (b) recording the employer's portion of the social security cost.

Debit this account when recording the quarterly tax payment to the Director of Internal Revenue. Also debit this account when recording downward adjustments of payroll vouchers and adjustments of journals recording the accrual of social security expense.

Balance represents the social security funds due Internal Revenue, disregarding unapplied deposits with the Federal Reserve bank. At no time should this balance exceed the balance of a calendar quarter (3 months).

State Withholding Taxes Payable
Account 1330

Credit represents deductions as recorded on payroll vouchers covering State taxes withheld from an employee of a sponsor.

Debit represents (a) payments to the State for taxes withheld, and (b) any downward adjustments of deduction previously recorded.

Balance represents the unpaid amount owing to the State. At no time should this balance exceed the deduction of a full calendar quarter.

State Unemployment Taxes Payable
Account 1340

Credit this account in the same amount as was recorded in account 1643--employer cost of fringe benefits for staff--other. This entry is recorded quarterly. This account will only be used when the sponsor is on an accrual or modified accrual basis. When the sponsor is on a cash basis, the contra to the expense account entry will be cash in bank--regular account.

Debit this account when recording the payment to the State unemployment agency.

Balance represents the unpaid amount due the State unemployment agency. At no time should this amount exceed the expense of any one calendar quarter.

City and State Retirement Taxes Payable
Account 1350

Credit this account for (a) retirement deductions set out on the payroll vouchers for all personnel subject to this tax and (b) the amount recorded as a cost to the sponsor in account 1643 -- employers cost of fringe benefits for staff -- other.

Debit this account when recording the payment to the State or city for this tax.

Balance represents the unpaid amount due the State or city. At no time should this amount exceed the liability of one calendar quarter.

Loans Payable
Account 1360

Credit this account for any monies advanced the sponsor pending the receipt of funds from the Department of Labor. No Federal funds will be recorded in this account.

Debit this account when recording the repayment of the loan.

Balance represents the outstanding balance of this account at the end of any month.

Accounts Payable
Account 1370

Credit this account when recording costs on an accrual basis (excluding liabilities for costs recorded in other liability accounts).

Debit this account when liquidating by payment or offset, liabilities established in this account.

Balance represents unpaid liabilities due at the end of any month.

Month-End Accruals
Account 1380

Credit this account for all unpaid liabilities on hand at the end of any month. This entry will constitute the on hand balance at the end of any month. Both payroll and other accruals will be recorded in this account.

Debit this account on the first day of the succeeding month in the exact amount of the previous month's accrual.

Note this account is to be used only where the sponsor desires to adopt this system of accrual accounting. The use of this account would negate the use of account 1370 -- accounts payable. At no time will this account be used at the termination of the contract.

Subsponsors Payable
Account 1390

Credit this account when recording costs on an accrual basis for services rendered by the subsponsor. This account includes invoices by the subsponsor which have been presented for payment but have not been paid.

Debit this account when liquidating by payment or offset liabilities established in this account.

Balance represents unpaid liabilities that have not been liquidated by payment or offset.

Contribution by Bureau of Work Programs
Account 1410

Credit this account when recording (a) the invoice billing the BWP (if on an accrual basis) or (b) funds received from the BWP (when on the cash basis of accounting).

Debit this account when (a) recording any funds due the BWP, generally at the conclusion of the contract (if on an accrual basis) or (b) when repayment has been made to BWP (when on the cash basis of accounting).

Balance represents the net amount of funds drawn or due from BWP. The balance of this account should equal that of account 1420 after submission of the final invoice to the Office of Financial and Management Services.

Cost Chargeable to Bureau of Work Programs
Account 1420

Debit this account for all costs recorded in the 1600 series of accounts. These costs, representing the full scope of expenses chargeable to BWP, should, after necessary adjustments to account 1410 -- contribution by BWP, be in exact agreement with that account. This entry should be made at the conclusion of the contract. This account will be debited when crediting (closing) the operating cost accounts.

Balance represents the net amount of BWP funds applied to (used) the contract. The entry will only be made at the termination of the contract.

Department of Labor - Property
Account 1430

Credit this account as a contra to Account 1201 debit entries for the amount of excess property furnished by the Department of Labor.

Debit this account as a contra entry to Account 1201 credit entries for excess property of the Department of Labor

Balance at all times will be a credit and in exact agreement with the total of excess property furnished by the Department of Labor, as reflected in property record cards.

Current Operating Costs
1600 Series of Accounts

Note the principle of recording the costs relative to these accounts has been explained in section G of this manual. The following account descriptions are the basis for charging each account. The sponsor may be on either a cash basis or on accrual basis of accounting.

Enrollee Wages - Wages for Work
Account 1601

Debit this account for enrollee wages which constitute the gross payroll cost including employee payroll deductions such as FICA and Federal and State withholding taxes. In those instances where the sponsor is on an accrual basis, a footnote should so indicate this fact. In the absence of such a notation, it will be assumed that the costs equal payments for wages including employee payroll deductions. See account descriptions 1310, 1320, and 1330.

Enrollee Wages - Wages for Other Paid Participation
Account 1602

Debit this account for enrollee wages which are paid to enrollees during the time they are not engaged in work-training or experience projects, but are receiving supportive services which include but are not limited to remedial education, counseling or medical treatment.

Enrollee Expense
Employer's Cost of Fringe Benefits - FICA
Account 1611

Debit this account for FICA cost. The entry will be recorded on a payment basis unless an accrual system is in effect. In those instances where FICA is included with other fringe benefits as a percentage of payroll, the cost applicable to FICA must be separately identified.

Enrollee Expense
Employer's Cost of Fringe Benefits - Workmen's Compensation
Account 1612

Debit this account for the following: (a) in those instances where the payment of workmen's compensation is a part of an allocation of cost of fringe benefits by a city government. Such costs will be recorded as expenses when reimbursement is made by the sponsor. (b) Where the sponsor is charged by the insurance company directly for workmen's compensation. (Costs will be recorded when paid unless an accrual system is in effect.) On the accrual basis, payments made at the beginning of an agreement will be established as a deferred charge. The expense of each month's workmen's compensation premium will be charged to this account; the offsetting credit being to the deferred charge account.

Enrollee Expense
Employer's Cost of Fringe Benefits -- Other
Account 1613

Debit this account for costs of (a) State or city retirement costs chargeable to sponsor (where employee is on loan to project), and (b) cost of State unemployment taxes where applicable, and (c) costs charged by city or State governments as a percentage of gross payroll cost (less portion allocated to social security and workmen's compensation).

Other Direct Enrollee Costs
Enrollee Transportation
Account 1621

Debit this account for cost of public transportation to move enrollees from one site to another during the course of a day. In addition, charge this account for allowable costs including chartered transportation where no public transportation is available to or from the work site.

Other Direct Enrollee Costs
Other Supportive Services
Account 1622

Debit this account for expenses properly chargeable to this account including costs for services outside of the staff of the sponsor, consultant fees, where allowable, and reimbursement expenses with other agencies, both public and private. A further example of costs is the partial payment of tuition costs for enrollees enrolled in schools or training classes where tuition costs are charged. Funds from this account may also be used to pay salaries of remedial teachers employed on a part-time basis if that situation is necessary due to lack of available classes for BWP enrollees.

Stipends
Account 1624

Debit this account for allowances from "Special Impact" funds paid to enrollees if the enrollees do not qualify for regular Manpower Development Training Act (MDTA) allowance.

Administration and Staff Services Costs
Salaries and Wages
Account 1630

The payroll accounts set out below define the substance of the account. The account treatment is the same in all instances. Costs shall be recorded gross when recording the payroll vouchers. Accruals of unpaid costs are allowed, but not required. Allocation of costs are a requirement where an individual's effort does not, in any specific category of assignment exceed 90 percent of his total effort.

Administration and Staff Services Costs
Salaries and Wages
Project Administration
Account 1631

Debit this account for the direction, coordination, selection of enrollees and housekeeping activities necessary to administer a BWP project. Personnel involved include the project director, work coordinators, and office staff engaged in overall project administration.

Administration and Staff Services Costs
Salaries and Wages
Recruitment
Account 1632

Debit this account for wages paid to clerical and staff personnel engaged in the actual contract work, and referral of applicants for the work-training project. Recruitment including the contract work such as outreach to public and private nonprofit agencies (including the State Employment Service), civic and voluntary associations, labor and business groups, members of the mass media and the youth themselves to provide them with information about the BWP program and to enlist those candidates who meet the requirements for enrollment.

Administration and Staff Services Costs
Salaries and Wages
Counseling Services
Account 1633

Debit this account for wages paid to personnel in the following categories: (a) full- or part-time counselors and psychometrists, (b) full- or part-time counselor trainees and counselor aides and indigenous workers working under the supervision of a qualified counselor and clerical workers to support this function.

Counseling services include the appraisal of the individual applicant's interests, aptitudes, abilities, personal characteristics, achievements, and other vocationally significant characteristics. This also includes assisting the individual through counseling interviews to achieve understandings, insights and attitudes that will help him to make a realistic appraisal of himself in relation to the requirements and opportunities of the fields of work and related training so that he can choose a suitable occupation and training plan. These services normally are made continuously available to enrollees during their participation in work-training programs to assist them in obtaining ultimate suitable employment.

Administration and Staff Services Costs
Salaries and Wages
Supervision
Account 1634

Debit this account for salaries and wages paid to personnel who are actually performing supervision of enrollees at the job site and clerical workers to support this function.

Supervision includes work supervision of enrollees while they are engaged in the work-training program. This includes such functions as: Orienting enrollees to the rules, policies, and procedures affecting wages, benefits, hours of work, rights and obligations, attendance and punctuality, conduct, work performance expectations,

instruction and supervision in job performance, maintenance of a reasonable workload in relation to the ability of the enrollee, and handling of work related problems. Supervisors normally contact counselors when problems arise which requires professional assistance.

Administration and Staff Services Costs
Salaries and Wages
Remedial Education
Account 1635

Debit this account for salaries and wages paid to staff personnel who are teachers of remedial education and clerical workers to support this function. Remedial education shall be regarded as elementary education in reading, writing, communication skills, and arithmetic. The techniques and content of the instruction should help the enrollee to adapt his general ability and aptitudes to the requirements of employment.

Administration and Staff Services Costs
Salaries and Wages
Job Development, Placement, Referral, and Followup
Account 1636

Debit this account for salaries of personnel specifically assigned for job development, placement, referral, and followup. BWP funds will be used for these services only when they are not available from Employment Service or other sources.

Job development refers to the process of developing new job training or educational opportunities for individuals, or groups of individuals, where no known openings exist. It is designed to create opportunities which will result in: (a) the improvement of the employability status of an enrollee upon completion of enrollment in BWP, or (b) the availability of training opportunities which will increase an enrollee's skills.

Referral and placement include processes whereby an enrollee is assisted in securing a job or to enter an educational or training opportunity.

Followup is the method by which the progress of an enrollee is measured and assistance is provided him as required after placement.

Administration and Staff Services Costs
Salaries and Wages
Other Services Supplied by Staff
Account 1637

Debit this account for services other than those described above. This may include medical examinations or supplemental vocational training. Normally these services are provided by other agencies. BWP finances such services only when the sponsor has demonstrated that they are essential to the success of the project and cannot be provided or financed by any other source.

Orientation
Account 1638

Debit this account for salaries and wages paid to personnel who are actually performing the various orientation functions at a job center, and the salaries and wages of clerical or other workers who support the orientation functions. "Orientation" may be defined as planned group sessions aimed at imparting knowledge concerning any or all of the following or related factors: various program options available, job-hunting techniques, functioning of the job market, and improvement of personal habits and attitudes.

Employer Cost of Fringe Benefits for Staff
FICA
Account 1641

Debit this account when recording the employer's portion of social security taxes applicable to staff salaries of the sponsor. This entry may be made concurrent with the preparation of Treasury form 941 or when accrued, if on an accrual basis. The contra account will be account 1010, cash in bank-regular account, or account 1320, social security taxes payable depending on whether the sponsor is on a cash or accrual basis.

Employer Cost of Fringe Benefits for Staff
Workmen's Compensation
Account 1642

Debit this account when (a) paying the workmen's compensation charge or (b) recording the liability for this cost if on an accrual basis.

Employer Cost of Fringe Benefits for Staff

Other
Account 1643

Debit this account for the cost of fringe benefits other than the payment for social security and workmen's compensation. Examples of such costs are (a) the payment of State unemployment taxes, (b) the sponsor's share of city and State retirement taxes, if properly chargeable under the agreement to the BWP and (c) any agreed to charge for fringe benefits by the State or city for employees on loan to the sponsor. This amount must first be allocated to (a) social security and (b) workmen's compensation before charging this account.

Administration and Staff Services Costs

Staff Travel Expenses

Transportation

Account 1651

Debit this account for the cost of transportation required in work assignments under the agreement. Conditions related to such expenses are set forth in the project proposal materials. These costs exclude per diem paid an employee.

Administration and Staff Services Costs

Staff Travel Expenses

Per Diem

Account 1652

Debit this account for per diem payments due officers and employees of the sponsor in lieu of actual costs while in a travel status outside the project area. Federal travel regulations generally apply as a guide for the sponsor and his staff. The sponsor will also be guided by local regulation, dictated by the parent organization (State, city government, etc.) where applicable.

Operational Costs

Supportive Costs

Office Equipment - Purchase

Account 1661

Debit this account for the cost of purchasing office equipment. Also charge this account for any freight costs relative to equipment recorded in this account including equipment received from GSA, or any other organization, free of cost. Costs chargeable to this item will include the cost of office equipment with a unit cost of \$100 or more or other items which by their nature will require property management controls (desks, chairs, etc.). A copy of the paid invoice and if more

than \$300, a copy of the executed document authorizing the purchase, shall be attached to the Detailed Statement of Costs. Contra account is cash or accounts payable.

Operation Costs
Supportive Costs
Project Equipment - Purchased
Account 1662

Debit this account for the cost of purchasing equipment used in the direct operation of the project. Excluded from this account would be any equipment identified to the administrative function of the sponsor. Such equipment is classified as office equipment and accordingly charged to account 1661. Also charge this account for all freight costs for project equipment, disregarding whether such equipment is purchased or donated free of charge. Costs chargeable to this item will include the cost of project equipment with a unit cost of \$100 or more or other items which by their nature will require property management controls and used in the program's job assignments or supplementary training and education program. The requirement to attach the paid invoice and purchase authorization is applicable. Contra account is cash or accounts payable.

Operational Costs
Supportive Costs
Rent
Account 1663

Debit this account for the cost of renting and renovation of public space. Payments must be in accordance with the terms of the rental agreement. Custodial services and supplies, included as part of the rental agreement, are to be charged to this account rather than account 1674 -- custodial services and supplies.

Operational Costs
Supportive Costs
Insurance and Bonding
Account 1664

Debit this account for the cost of insurance and bonding including fidelity bonds and insurance other than costs chargeable as fringe benefits, both for enrollees and staff. Hospitalization and retirement insurance are examples of fringe benefit charges.

Office Equipment - Rental or Use
Account 1665

Debit this account for renting or use charges for office equipment.

Project Equipment - Rental or Use
Account 1666

Debit this account for renting or use charges of equipment used in direct operation of the project.

Training Costs
Account 1667

Debit this account for training costs incurred in the On-the-Job Training Program (OJT) and the Work-Training in Industry Program (WTI).

Operational Costs
Other Direct Costs
Expendable Office Supplies
Account 1671

Debit this account for the purchase of all supplies and minor items of equipment used by enrollees and in connection with the administration cost of the project. Office equipment costing \$100 or less will be recorded in this account. Included in this account will be such items as payroll records, time and attendance cards, typewriter supplies, and paper supplies.

Operational Costs
Other Direct Costs
Communications
Account 1672

Debit this account for telephone service (including long-distance calls), telegrams and cables, postage and messenger service, and similar services properly chargeable to the BWP under the terms of the contract agreement.

Operational Costs
Other Direct Costs
Utility Costs
Account 1673

Debit this account for the cost of securing electricity, heat, air-conditioning, water, and other utilities considered a proper charge to BWP under the contract. Services of this nature, included in the rental agreement as a service supplied by the lessor, will be charged to the rent account.

Operational Costs
Other Direct Costs
Custodial Services and Supplies
Account 1674

Debit this account for the cost of contract janitorial labor and supplies used in maintaining the facilities of the project. Such services provided as part of the rental agreement will be included as a charge to account 1663, rent. Service supplied by staff will be charged to account 1631, salaries and wages-- project administration.

Operational Costs
Other Direct Costs
General
Account 1675

Debit this account for all operational costs not otherwise chargeable to other accounts in the 1670 series. Examples of such costs are accounting and bookkeeping services, labor relations costs, dues and subscriptions and legal and medical costs. The terms of the contract dictate the scope of expenses properly chargeable to the BWP.

Undistributed (Indirect) Costs
Account 1680

Debit this account for any costs properly chargeable as a program activity under the contract not covered by any other account in the 1600 series.

Subagreement Costs
Account 1690

Debit this account for the cost of services carried out through agreements with other private nonprofit or public organizations. These costs must be directly related to the project provision therefore acknowledged within the terms of the contract agreement and must be actual costs incurred.

J. ACCOUNTING PROCEDURE GUIDELINES

1. This section sets out an approach to (a) ordering, (b) receiving, (c) paying, (d) journalizing, and (e) general ledger posting of transactions relative to this operation. This section is not a requirement imposed on the BWP sponsor; however, the principles set out should be followed to assure an orderly and auditable set of records. The discussion will be by category of expense.

- a. Payroll
Enrollees
Staff Salaries

- (1) Establishing the enrollee and staff members into the organization

- (a) Enrollee - BWP Form 16

- (b) Staff member - Employee application and appointment form adopted by the sponsor.

These records must indicate the rate of pay on an hourly basis for enrollees and weekly pay for the staff; and the job classification of the staff.

- (2) Evidence of services performed

- (a) Enrollee - Time and attendance records, signed by both the enrollees and their supervisors, must be in evidence prior to placing the enrollees in line for payment. The payroll unit will verify the extensions to assure the accuracy of the services claimed. These records may be on a weekly or bi-weekly basis, depending on the frequency of payment of the payroll. Counseling hours, not payable by BWP, should be separately identified.

(b) Staff - Time and attendance records are required for all staff personnel except the project director and his top staff. Conditions of leave, both annual and sick, will apply in accordance with the policies of the sponsor. These conditions shall be spelled out in the basic contract agreement.

(3) Payment of payroll

- (a) Separate payroll vouchers will be prepared for enrollees and staff personnel. The voucher will be supported by a listing of the enrollees and staff, detailing the gross pay of each individual, the individual deductions, and the net pay due. The vouchers will be verified to the time and attendance reports and test checked to determine the accuracy of the data if prepared by data processing equipment. The manual preparation of the voucher would have required the validity of the entry concurrent with the recording of the transaction of the payroll voucher.
- (b) The distribution of the signed enrollee and staff payroll checks will either be through the supervisor or by direct mailing to the home. Surprise check distributions shall be made by the sponsor's internal audit staff, or administrative or program employees having no direct relationship to attendance approval or payroll preparation. In no instance will distribution be made by the payroll unit. Neither should that unit ever have access to the checks after signature by the project director or his designee.

(4) Journalizing the payroll voucher

- (a) The total of the payroll voucher will be recorded in the payroll journal, rather than detailing the payment of each individual in the journal. The check stub entries, net, relative to a pay period, will be totaled and verified to the net disbursement entry on the journal. Further verification of the entry will be accomplished when drawing a single check out of the regular checking account for deposit in the payroll account. This latter entry will be in the exact amount of the payroll voucher, net. Where data processing equipment is used in the preparation of payroll checks, a listing of such checks will be attached to the applicable payroll voucher and schedule. It is essential to verify the listings to the payroll voucher prior to the release of the checks. This is especially true where outside services units are utilized in the preparation of payroll checks.

- (b) In order to maintain account distribution of the staff personnel, the payroll schedule should detail, where possible, the salaries by account position. Where allocations are required, the allocation of cost should be recorded on the schedule to allow direct recording of the costs into the proper salary account.

(5) General Ledger Posting

The payroll journal, maintained on a monthly basis, will be totaled, and the footings checked at the end of the month. Postings from the journal will be on an account basis to the general ledger. Control accounts as such will not be required to be maintained except at the discretion of the sponsor. Indicate by a checkmark on the payroll journal to evidence that the entry has been made in the ledger.

b. Supplies and Materials

Office Equipment - Purchased - Account 1661
Project Equipment - Purchased - Account 1662
Office Equipment - Rental or use - Account 1665
Project Equipment - Rental or use - Account 1666
Expendable Office Supplies - Account 1671
Custodial Services and Supplies - Account 1674
General - Account 1675

(1) Ordering the purchase item

- (a) More frequently than not, minor cost items will be paid out of the petty cash fund. If such is the case, the order form will be a petty cash slip. Orders placed for delivery at a time subsequent to the placing of the order will be by a form normally utilized by the sponsor in his operation. The order must be signed by an authorized individual.
- (b) Orders placed will be forwarded to the vendor, a copy of which will be placed in a file jacket of unpaid orders. The account number to be charged will be indicated on the order. No journal entry will be made at this time.

(2) Receipt of ordered item

When the goods ordered are delivered, the delivery ticket, signed by the recipient as (1) delivered as ordered, and (2) received in good condition, will be attached to the order document awaiting an invoice from the vendor. Normally, the point of receipt will be in possession of a copy of the order.

(3) Payment process

(a) As stated above, the petty cash process is a concurrent action, recording the purchase in the petty cash register at the time of procuring the item. The paid invoice, frequently no more than a cash register receipt, will be stapled onto the petty cash voucher.

(b) Upon receipt of the invoice, the order and receiving report will be removed from the unpaid file. A check will then be drawn and submitted to the vendor together with a copy of the invoice or a portion of the invoice required to be returned with the payment. The invoice will then be stapled to the order and the receiving report, noted as to the check number, date of payment, and amount, and filed alphabetically by vendor in a paid file by month of payment.

(4) Journalizing the payment

(a) Postings from the checkbook to the check disbursement journal will be in accordance with the format proposed in section III of this manual. Specifically, the following data are posted:

1. date of check,
2. payee,
3. check number,
4. amount, and
5. account charged.

Payments will be recorded net of any discount.

(b) Petty cash expenditures will be recorded in the check disbursement journal at the time the fund is reimbursed. The check will be in the amount of the expense summary as described in section G and distributed to the accounts as indicated in the petty cash register. The check number will be recorded adjacent to the total amount on the petty cash slips covering one check payment. The petty cash slips will be stapled together and filed in a petty cash paid file for the month. At the end of the month, the transactions in the journal are totaled and verified by a cross-checking process.

(5) General Ledger Recording

Postings are made once a month from the check disbursement journal. The summary of transactions, totaled by account, are recorded by detail account in the general ledger. It is not necessary to post to or to maintain control accounts as set out in Section I - Chart of Accounts.

c. Transportation Costs

Enrollee Transportation - Account 1621

Staff Travel Expenses - Transportation - Account 1651

Costs of this nature will not follow the normal accounting process described in b above. These costs, reimbursable in nature, generally will be handled through the petty cash fund. A statement by the (1) supervisor of the enrollees or (2) a signed statement of cost by a staff member, properly approved by a designated official, will serve as a basis for payment. The aforementioned documents must be maintained in support of the petty cash payment.

d. Cost of Fringe Benefits

Enrollees

FICA - Account 1611

Workmen's Compensation - Account 1612

Other - Account 1613

Staff

FICA - Account 1641

Workmen's Compensation - Account 1642

Other - Account 1643

(1) Placing the order

In only one instance above, workmen's compensation, would there be an order placed. A copy of the agreement with the insurance company must be on file in support of the order.

(2) Incurring the expense

- (a) With respect to workmen's compensation, the total amount of the contract is due when submitted by the insurance company, and will be recorded in full as expense when paid, except those instances where the sponsor keeps accounts on an accrual basis. Accrual accounting requires the payment be charged to a deferred expense account which will be reduced each month by a pro rata charge to expense.
- (b) FICA costs will be determined either (1) following each payroll, or (2) at the end of a calendar quarter when preparing the Federal tax form 941. It is preferred that the former approach be taken.

(3) Payment of fringe costs

- (a) Workmen's compensation payments will be based on an invoice received from the company. Keep in mind that this billing is an estimate subject to adjustment at the conclusion of the operation by the sponsor under the specific agreement. When recording the payment, note the check number, date of payment, and amount on the face of the invoice copy retained by the sponsor. It is suggested that the sponsor secure several rubber stamps containing these data.
- (b) FICA payments are made at the end of each calendar quarter, and are due in the Internal Revenue Office by the end of the month following the quarter. A copy of form 941 is maintained in the files of the sponsor. Final payment data, plus evidence of Federal Reserve bank deposits must be noted on the retained copy as well as the form submitted to the Director of the Internal Revenue.

(4) Journalizing the transaction

- (a) Workmen's compensation liability accruals will normally not be recorded except where the sponsor is following an accrual system of accounting. Accordingly, the expense will be recorded in the check disbursement journal concurrent with the disbursement.

(b) FICA accruals, preferred but not necessary, will be journalized in the general journal. In this instance, the entry recording the payment will credit liability account 1320 -- social security taxes payable. If a previous liability has not been established, the check recording the payment will breakout (on the check stub) the employer's portion of the FICA payment with that portion of the payment being charged to account 1611.

(5) General ledger recording

Workmen's compensation and FICA, if accrued, will be posted from the general journal as an individual entry. If the expense was recorded in the check disbursement journal, it will be recorded in the general ledger in the same manner as (4) (b) above.

e. Miscellaneous Expense

Other Supportive Services - Account 1622

Staff Travel - Per Diem - Account 1652

Rent - Account 1663

Insurance and Bonding - Account 1664

Communication - Account 1672

Utility Costs - Account 1673

(1) Placing the order

(a) Other supportive services - generally apply to services of consultants. There must be a signed contract on file indicating (1) the type and extent of services to be rendered, (2) the agreed to remuneration, (3) the termination date of the agreement, and (4) data required as support for the billing.

(b) Staff travel - Per diem expenses, except as relates to the project director should be covered by an authorization for such travel signed by the project director. The policy on reimbursable travel costs as spelled out in the project proposal materials prevails with respect to the allowability of cost.

(c) Rent - agreement must be reduced to writing spelling out

1. monthly cost of rent,
2. insurance required to be carried by sponsor,
3. insurance coverage carried by lessee,
4. services (such as heat, light and power, and custodial) included in rent base,
5. tax escalation clauses if applicable, and
6. termination date of contract.

(d) Insurance and bonding - agreements must be in writing and available for audit review. A summary listing of such policies should be maintained on file to assure that all necessary policies and bonding agreements are in effect.

(e) Utility and communications - expenses are not covered by a written agreement. A statement should be available on the ordering of telephone hookups, extensions, etc., that were installed by the telephone company.

(2) Receipt of service

(a) Other supportive services will be evidenced by a billing from the consultant or organization, certifying as to the services rendered. This should be signed, as approved, by the project director. Verification of the cost, based on rate of pay, should be made with the original contract agreement. The period of service covered by the billing should be noted thereon.

(b) Staff travel - Per diem costs should be submitted on a travel voucher or other type of document or form used by the sponsor. It should be signed by the traveler and approved by the project director or his designee. The data should be submitted in sufficient detail to permit an adequate review prior to payment.

(c) Rent will be paid automatically without requiring the submission of an invoice by the lessor.

(d) Insurance and bonding cost normally will be billed concurrent with the receipt of the policy. Verify the invoice to the conditions of the policy to assure that the charges are in order.

(e) Utility and communications costs normally are not susceptible to audit review. If, however, the billing appears to be out of line, a verification of this fact can be made with the companies involved. The invoices should be placed in the unpaid invoice file after any necessary review.

(3) Payment of invoice

When drawing the checks for these expenses (except rent), note the (a) check number, (b) amount, and (c) date of payment on the invoice form retained by the sponsor. The payment of rent, not covered by an invoice, should be an automatic operation. It may be helpful to maintain a schedule of rent payments on file in the unpaid invoice file.

(4) Journalizing the payments

These expenses will be recorded from the checkbook supported by the related paid vouchers into the check disbursement journal. Since this chapter presents the cash basis of accounting, the entry in the check disbursement journal will be a direct charge to the detailed expense account.

(5) Recording entries in general ledger

This entry is the same as that outlined in the paragraph above.

K. CLOSING OF THE BOOKS

1. A separate set of books must be maintained under each contract. With the culmination of one contract, the current operating costs will be closed out and established as a one-line entry in account 1420 -- current year costs chargeable to BWP. This action takes place after assurance that every possible cost has been firmed up as final with no further possibilities of future costs developing. An example of this entry follows (general journal entry):

Debit: Account 1420 - Current year costs chargeable to
 BWP\$100,000.00

Credit:

Account 1601 - Enrollee wages	\$80,000.00
Account 1611 - FICA	2,500.00
Account 1612 - Workmen's compensation	5,000.00
Account 1631 - Project administration	10,000.00
Account 1632 - Recruitment	2,500.00

To close all operating accounts to equity based on final costs under the current contract.

Differences between funds contributed by the BWP and the total reimbursed costs will serve as the basis for the following entries:

(1) Debit: Account 1410 - Contribution by BWP \$5,000.00

Credit:

Account 1370 - Accounts payable	_____	,
or- Account 1010 - Cash in bank - Regular account	_____	,\$5,000.00
	_____	,

(2) Debit: Account 1370 - Accounts payable \$5,000.00

Credit: Account 1010 - Cash in bank - Regular account.... \$5,000.00

To record payment of funds to BWP based on excess of BWP funds over a final computation of related costs.

2. At this stage, cash funds available should be in exact agreement with the payable accounts. The balance in the equity account will now be at zero. The petty cash funds will have been transferred back to the regular checking account prior to closing. The initial deposit of funds from the payroll checking account will also have been transferred back to the regular checking account.
3. Should a deficiency of contributed funds develop at this stage of the operation, negotiations with regional personnel should determine the extent of liability acceptance by the BWP and the need for contract amendment.
4. If the sponsor or contractor is interested in obtaining detail information on contract close-out procedures, he may read chapter 3110, Contracting for Manpower Administration Programs, paragraph 3117--Close out of Contract Records.

L. REPORTING REQUIREMENTS

1. Administrative Notice No. 3-66 (Feb. 28, 1966), contains detailed instructions concerning invoicing and reporting costs for sponsors. The CEP contractors will follow instructions for invoicing and reporting costs dated June 16, 1967.
2. Fiscal reporting requirements under the terms of the agreement are limited to a monthly submission titled, "BWP Sponsor's Detailed Statement of Costs," exhibit 1. This statement signed by the chief accountant of the project, normally is submitted to BWP in support of an invoice billing the BWP for costs incurred. In the absence of the need for funds, however, it is essential that this report be submitted each month to be received by BWP no+ later than the 10th of the month following. There will be no exception to this condition since the data are required in connection with the development of cost data on a detailed basis for the entire BWP program. CEP contractors will use "Contractors Detailed Statement of Costs," exhibit 3.
3. Instructions relative to the cost report require the use of expenses based on the books of account. The form sets out the account groupings where the control account rather than the detail account is reported. As an example, the report has one line for the other direct costs control account 1670. This line will contain all of the detail accounts in the 167 series. This approach also applied to control account 1650, staff travel expense; account 1640, employer's cost of fringe benefits for staff; and account 1610, employer's cost of fringe benefits for enrollees. Relationships between cost accounts per the general ledger and the monthly detailed statement of costs follow:

Relationship of General Ledger Accounts to Monthly Detailed Statement of Costs

	General Ledger Accounts		Statement of Costs
	<u>Control</u>	<u>Detail</u>	
I. <u>Enrollee Expenses</u>			
Enrollee wages	<u>1600</u>		
Enrollee wages for work	----	1601	1601
Enrollee wages for other paid participation	----	1602	1602
Employer's cost of fringe benefits	<u>1610</u>		
FICA	----	1611	----
Workmen's Compensation	----	1612	----
Other	----	1613	----
Other direct enrollee costs	1620		
Enrollee transportation		1621	1621
Other supportive services	----	1622	1622
Stipends	----	1624	1624

cont'd.

	General Ledger Accounts		Statement
	<u>Control</u>	<u>Detail</u>	<u>of Costs</u>
II. <u>Project Costs</u>			
A. Salaries and wages	<u>1630</u>	----	<u>1630</u>
Project administration	----	1631	<u>1631</u>
Recruitment	----	1632	1632
Counseling services	----	1633	1633
Supervision	----	1634	1634
Remedial education	----	1635	1635
Job development, placement, referral and followup	----	1636	1636
Other services supplied by staff	----	1637	1637
Orientation	----	1638	1638
B. Employer cost of fringe benefits for staff	<u>1640</u>	----	<u>1640</u>
FICA	----	1641	----
Workmen's compensation	----	1642	----
Other	----	1643	----
C. Staff travel expenses	<u>1650</u>	----	<u>1650</u>
Transportation	----	1651	----
Per diem	----	1652	----
III. <u>Operational Costs</u>			
Supportive costs	<u>1660</u>	----	----
Office equipment--purchased	----	1661	1661
Project equipment--purchased	----	1662	1662
Office equipment--rental or use	----	1665	1665
Project equipment--rental or use	----	1666	1666
Rent	----	1663	1663
Insurance and bonding	----	1664	1664
Training costs	----	1667	1667
Other direct costs	1670	----	1670
Expendable office supplies	----	1671	----
Communications	----	1672	----
Utility cost	----	1673	----
Custodial services and supplies	----	1674	----
General	----	1675	----
IV. <u>Undistributed (Indirect) Costs</u>	<u>1680</u>	----	<u>1680</u>
V. <u>Subagreement Costs</u>	<u>1690</u>	1690	<u>1690</u>

4. In addition to the above statement the sponsor will prepare each month a reconciliation of costs per BWF Sponsor's Detailed Statement of Costs to check disbursements as illustrated in Exhibit 2. It reconciles cash increases and decreases to costs incurred and related liabilities thus providing the Sponsor with a method of validating the Detailed Statement of Costs. The reconciliation statement will be retained by the Sponsor for review by the auditors.

Exhibit 1 - p. 1

U.S. DEPT. OF LABOR - MANPOWER ADMINISTRATION BUREAU OF WORK PROGRAMS		1. AGREEMENT NUMBER						2. IN SUPPORT OF INVOICE NO.:									
SPONSOR'S DETAILED STATEMENT OF COSTS		3. FUNDS REQUESTED FOR		4. WTI (NYC)		5. OM		6. NC		7. SI		8. SUMM (NYC)		9. OTHER		10. 30	
		1. IS (NYC)		2. OS (NYC)		3. NC		4. SI		5. SI		6. SI		7. SI		8. SI	
4. SPONSOR'S NAME (Agency or Organization)		5. CUMULATIVE COST PERIOD						6. NUMBER OF PAID ENROLLEE HOURS									
		a. FROM						b. TO DATE									
7. PAYMENT INFORMATION		1ST PERIOD		2ND PERIOD		3RD PERIOD		4TH PERIOD		5TH PERIOD							
2. PAYROLL DATE		5F 51-54		55-58		59-62		63-66		67-70							
b. NUMBER OF ENROLLEES ON THE PAYROLL		71-75		5G 31-35		36-40		41-45		46-50							
c. TOTAL HOURS COMPENSATED FOR WORK		51-56		57-62		63-68		69-74		75-80							
d. TOTAL HOURS COMPENSATED FOR OTHER PARTICIPATION		5H 31-36		37-42		43-48		49-54		5H 55-60							
e. AMOUNT OF ENROLLEE PAYROLL		61-65		66-70		71-75		SI 31-35		36-40							
COST CATEGORY	ACCT. NO.	PROJECT BUDGET		CUMULATIVE COSTS		COSTS FOR REPORT PERIOD											
		SPONSOR (a)	FEDERAL (b)	SPONSOR (c)	FEDERAL (d)	SPONSOR (e)	FEDERAL (f)										
I. ENROLLEE COSTS																	
A. WAGES																	
1. For Work.....																	
1601																	
2. For Other Paid Participation.....																	
1602																	
3. TOTAL WAGES (Add 1 and 2)																	
1610																	
B. EMPLOYER'S COST OF FRINGE BENEFITS																	
1621																	
1622																	
C. TRANSPORTATION																	
D. SUPP. SVCS. NOT SUPPLIED BY STAFF																	
5J 31-35																	
61-65																	
71-75																	
76-80																	
36-40																	
TOTAL, SECTION I (Add A3, B, C, and D)																	
II. STAFF COSTS																	
A. SALARIES & WAGES																	
1. Proj. Adm.																	
1631																	
2. Recruitment.....																	
1632																	
3. Counseling Services.....																	
1633																	
4. Supervision																	
1634																	
5. Remedial Education.....																	
1635																	
6. Job Development, Placement, Referral, Follow-Up...																	
41-45																	
51-55																	
61-65																	
71-75																	
31-35																	
46-50																	
56-60																	
66-70																	
76-80																	
36-40																	
41-45																	

U.S. DEPT. OF LABOR - MANPOWER ADMINISTRATION BUREAU OF WORK PROGRAMS		1. AGREEMENT NUMBER				3-11		2. IN SUPPORT OF INVOICE NO.:	
		3. FUNDS REQUESTED FOR		4. WT1 (NYC)		5. OM		6. OTHER	
SPONSOR'S DETAILED STATEMENT OF COSTS (Continued)		1. 15 (NYC)		2. 05 (NYC)		3. SUMM. (NYC)		15-29	
		7. 51		8. 51		9. 37			
COST CATEGORY	ACCT. NO.	PROJECT BUDGET		CUMULATIVE COSTS		COSTS FOR REPORT PERIOD			
		SPONSOR (a)	FEDERAL (b)	SPONSOR (c)	FEDERAL (d)	SPONSOR (e)	FEDERAL (f)		
7. Other Supp. Svcs. Supplied by Staff.....	1637					51-55	56-67		
8. TOTAL SALARIES & WAGES (Add items A1 through A7)	1630								
B. EMPLOYER'S COST OF FRINGE BENEFITS.....	1640					61-65	66-70		
C. TRAVEL EXPENSES	1650					71-75	76-90		
TOTAL, SECTION II (Add A6, B, and C)									
III. OPERATIONAL COSTS									
A. EQUIPMENT									
1. Office Equipment									
a. Purchase	1661					5L 31-35	36-47		
b. Rental & Use	1665					11-45	46-51		
2. Project Equipment									
a. Purchase	1662					51-55	56-63		
b. Rental & Use	1666					61-65	66-70		
B. RENT.....	1663					71-75	76-80		
C. INSURANCE AND BONDING..	1664					5M 31-35	36-40		
D. TRAINING COSTS.....	1667					41-45	46-50		
E. OTHER DIRECT COSTS.....	1670					51-55	56-61		
F. INDIRECT COSTS.....	1680					61-65	66-70		
TOTAL, SECTION III (Add A1e, A1b, A2e, A2b, B, C, D, E, and F)									
IV. SUBAGREEMENT COSTS	1690					5N 31-35	36-40		
V. TOTAL COSTS						41-46	47-52		



Exhibit 2

Reconciliation of Costs Per BWP Sponsor's Detailed Statement of Costs to Check
Disbursements of, 196...

Cash on hand and in bank - beginning of month:		
1. Regular checking account-----	\$10,000.00	
2. Payroll checking account-----	500.00	
3. Petty cash fund-----	500.00	
	<hr/>	
Total-----		\$11,000.00
Add: Funds received from BWP during month -----		10,000.00
		<hr/>
		21,000.00
Less:		
1. Liabilities end of previous month:		
a. Tax liabilities -----	\$1,000.00	
b. Other liabilities -----	1,000.00	
	<hr/>	
Total-----	\$2,000.00	
2. Current month's cost per BWP Sponsor's detailed statement of costs-----	10,000.00	
3. Receivables--end of current month (include deposits with Federal Reserve bank)-----	2,000.00	
Total-----		14,000.00
		<hr/>
		7,000.00
Add:		
1. Current month's liability accruals:		
a. Tax liability-----	\$1,000.00	
b. Other liability-----	800.00	
	<hr/>	
Total-----	\$1,800.00	
2. Receivable balance--end of previous month (include deposit with Federal Reserve bank)-	2,500.00	
Total-----		4,300.00
		<hr/>
		11,300.00
		<hr/> <hr/>
Cash balance--end of month-----		11,300.00
Made up of:		
1. Regular checking account-----	\$10,300.00	
2. Payroll checking account-----	500.00	
3. Petty cash fund-----	500.00	
	<hr/>	
	11,300.00	
	<hr/> <hr/>	

CONTRACTOR'S DETAILED STATEMENT OF COSTS

1. CONTRACT NUMBER 2. IN SUPPORT OF INVOICE NO.:

3A. FUNDS REQUESTED FOR CEP PROGRAM 1 NYC 2 MDTA 3 OM 4 NC 5 SI 6 OTHER

3B. FUNDS REQUESTED FOR BWP CONTRACTORS ONLY 1 NYC 2 OS (NYC) 3 SUMM (NYC) 4 WF (NYC) 5 OM 6 NC 7 SI 8 OTHER (Specify)

4. CONTRACTOR'S NAME (Agency or Organization) 5. CUMULATIVE COST PERIOD 6. NUMBER OF PAID ENROLLEE HOURS

7. PAYROLL INFORMATION

PAYROLL DATE	1ST PERIOD		2D PERIOD		3D PERIOD		4TH PERIOD		5TH PERIOD	
	a. FROM	b. TO	a. FROM	b. TO	a. FROM	b. TO	a. FROM	b. TO	a. FROM	b. TO
a. PAYROLL DATE										
b. NUMBER OF ENROLLEES ON THE PAYROLL										
c. TOTAL HOURS COMPENSATED FOR WORK										
d. TOTAL HOURS COMPENSATED FOR OTHER PARTICIPATION										
e. AMOUNT OF ENROLLEE PAYROLL										

8. COST CATEGORY ACCT. NO. PROJECT BUDGET CUMULATIVE COSTS COSTS FOR REPORT PERIOD

COST CATEGORY	ACCT. NO.	PROJECT BUDGET		CUMULATIVE COSTS		COSTS FOR REPORT PERIOD	
		Contractor (a)	Federal (b)	Contractor (c)	Federal (d)	Contractor (e)	Federal (f)
I. ENROLLEE COSTS							
A. WAGES							
1. For Work	1601						
2. For Other Paid Participation	1602						
3. TOTAL WAGES (Add 1 and 2)							
B. EMPLOYER'S COST OF FRINGE BENEFITS							
	1610						
	1621						
C. TRANSPORTATION							
	1622						
D. SUPP. SVCS. NOT SUPPLIED BY STAFF							
	1624						
E. STIPENDS							
TOTAL SECTION I (Add A3, B, C, D, and E)							
II. STAFF COSTS							
A. SALARIES & WAGES							
1. Proj. Adm.	1631						
2. Recruitment	1632						
3. Counseling Services	1633						
4. Supervision	1634						
5. Remedial Education	1635						
6. Job Development, Placement, Referral, Follow-Up	1636						

HI 158

CONTRACTOR'S DETAILED STATEMENT OF COSTS—Continued **1. CONTRACT NUMBER** **Exhibit 3 - p. 2** **2. IN SUPPORT OF INVOICE NO.**

COST CATEGORY	3A. FUNDS REQUESTED FOR CEP PROGRAM				3B. FUNDS REQUESTED FOR BWP CONTRACTS ONLY			CUMULATIVE COSTS			
	1 <input type="checkbox"/> NYC	2 <input type="checkbox"/> MOTA	3 <input type="checkbox"/> OM	4 <input type="checkbox"/> NC	4 <input type="checkbox"/> WT (NYC)	5 <input type="checkbox"/> OM	6 <input type="checkbox"/> NC	CONTRACTOR (c)	FEDERAL (d)	CONTRACTOR (e)	FEDERAL (f)
	PROJECT BUDGET			COSTS FOR REPORT PERIOD							
	ACCT. NO.	CONTRACTOR (a)	FEDERAL (b)	CONTRACTOR (c)	FEDERAL (d)	CONTRACTOR (e)	FEDERAL (f)				
7. Orientation	1638										
8. Other Supp. Svcs. Supplied by Staff	1637										
9. TOTAL SALARIES & WAGES (A1 thru A8)	1630										
B. EMPLOYER'S COST OF FRINGE BENEFITS	1640										
C. TRAVEL EXPENSES	1650										
TOTAL, SECTION II (Add A9, B, and C)											
III. OPERATIONAL COSTS											
A. EQUIPMENT											
1. Office Equipment											
a. Purchase	1661										
b. Rental & Use	1665										
2. Project Equipment											
a. Purchase	1662										
b. Rental & Use	1666										
B. RENT	1663										
C. INSURANCE AND BONDING	1664										
D. TRAINING COSTS	1667										
E. OTHER DIRECT COSTS	1670										
F. INDIRECT COSTS	1680										
TOTAL, SECTION III											
IV. SUBAGREEMENT COSTS	1690										
V. TOTAL COSTS											

II-59

**CONTRACTOR'S DETAILED STATEMENT OF COSTS
FOR SUB-CONTRACTED ON-THE-JOB TRAINING**

CONTRACT NO.
ACCOUNTING NO.

STATEMENT OF COSTS NO.

SUB-CONTRACTOR	NO. OF TRAINEES		CUMULATIVE AMOUNT PAID TO DATE
	Authorized	In Training	

CHAPTER III

PHYSICAL AND FINANCIAL CONTROL OF PERSONAL PROPERTY

A. POLICY AND PURPOSE OF ISSUANCE

1. Section II, D, Part B of the Project Proposal Materials, issued by the U.S. Department of Labor, Manpower Administration, Neighborhood Youth Corps, states in part "...All Equipment purchased under terms of the agreement becomes the property of the Federal Government ..."
2. Part 3200, Chapter 3220, Property Handbook for Contracting Personnel, sets forth the guidelines and procedures to be followed by Manpower Administration sponsors for administering Government property which is purchased or acquired as excess property. There will be no variance as to what is defined in Section B as personal property, as contrasted with the categorical description of supplies and materials.
3. This chapter of the accounting manual spells out the technique of controlling personal property through an asset account in the general ledger. This does not follow the normal procedures of capitalizing in an asset account, and recording in a property record, the purchase of personal property to be capitalized. It is a requirement that all purchases of equipment chargeable to BWP be recorded as operating cost (account 1661, office equipment--purchased, or, account 1662, project equipment--purchased; account 1671, expendable office supplies; account 1665, office equipment--rental or use; account 1666, project equipment--rental or use). A copy of the executed document, authorizing the purchase of property, must accompany Report Form BWP-25 to the Manpower Administration.
4. In order to meet the requirement of asset control over property subject to recordkeeping and, at the same time charge such purchase to an operating cost account, the following procedure is adapted:
 - a. Record purchase in operating cost account (accounts 1661, 1662, or 1671).
 - b. Record equipment, subject to property control, on a property record card. (Sample of property record card on p. III-9.)

- c. Debit the asset accounts 1661 and 1662 at the same time crediting Furniture, fixtures and equipment-Contra credit account and/or Department of Labor-Property in appropriate amounts as recorded in b above.
5. It can be seen by this technique that asset control will be established over the details as maintained in the property record cards. Any action of disposal will, of course, result in an entry on the asset and related contribution to BWP Furniture, fixtures and equipment-Contra credit account and/or Department of Labor-Property accounts, concurrent with the entry on the property record card. The general policy of inventory control is spelled out in detail in section C, maintenance procedures and organizational responsibilities.

B. PERSONAL PROPERTY DEFINED

1. Nonexpendable personal property is any article which (a) has a service life in excess of one year, (b) is either complete within itself or is a major component of another item of property (the item procured which is in the final analysis a component of another item will lose its identity as an item of capitalization--except as part of the new item of equipment), (c) by definition cannot be described either as supplies or materials.
2. For purpose of maintenance control, nonexpendable personal property is treated as either capitalized or expensed. Control of non-expendable equipment will be as follows:
 - a. Unit cost of \$100 or more is capitalized and therefore controlled by property records.
 - b. Unit cost of less than \$100 is expensed and property record control should be maintained if the item's nature is such that it does not lose its identity (chairs, desks, etc.).
3. The initial accounting treatment, both with respect to (a) equipment maintenance under record maintenance control and (b) equipment expenses when purchased, is the same. In both instances, the BWP equipment accounts (office and project equipment is charged when recording the payment for the articles procured. The asset and related valuation control described above applies only to 2(a).

4. Unit values as defined in paragraphs a and b above refer to the cost of a new item of equipment. The procurement or securing of second-hand property either at no cost at all or a nominal charge will be included in part 2(a).....equipment.
5. Normally, freight cost is included as part of the purchase price of an article of equipment. Where freight costs are (a) identified to a specific item and (b) is the charge from factory to project (as against the freight cost for movement within the project), the freight cost will be added to the purchase price of the article procured and, accordingly, will be capitalized.
6. Considering the nature of the BWP operation, normally heavy in administrative and office cost, the following categories of equipment will be placed under recordkeeping control.
 - a. Office furniture (including tables, chairs, file cabinets, bookcases, costumers, lamps, and rugs)
 - b. Office machines (including adding machines, calculators, dictating machines, duplicating equipment, typewriters, and time stamps)
 - c. Project equipment (generally covered by types of procurement described in pars. a and b above)
7. Expendable personal property disregarding its cost value is property which is (a) consumed when used, or (b) has a utilization life of less than one year. Such property is usually supplies and materials, as contrasted to nonexpendable (office or project)equipment.
8. Supplies and materials used in the development of an item considered to be of a nonexpendable nature will nevertheless be charged to the supply and material account. The assembled item (possibly a work-table constructed from lumber) will be placed under property record maintenance control.

C. MAINTENANCE PROCEDURES AND ORGANIZATIONAL RESPONSIBILITIES

1. As large quantities of Federal property are not utilized in the typical BWP project, recordkeeping will be held to a minimum, consistent with the policy standards set out in section A of this issuance. This section does not explain the accounting treatment of property procurement, which subject is fully covered both in chapter II of this

manual and in the project proposal materials. As a prerequisite to complying with the maintenance procedures set out below, it is essential to initially consider the item of procurement as (a) within the scope of record maintenance or (b) excluded from recordkeeping.

2. NEWLY PURCHASED EQUIPMENT

a. Receipt of Property

- (1) When the property is delivered to the project, the individual signing for the delivery must determine that:
(a) the equipment is that which was ordered, (b) the equipment was received in good condition, and (c) the quantity received is in agreement with the order.
- (2) A file record of purchase orders should be maintained containing Equipment on order as well as equipment received. After noting the necessary data (see above) on the receiving report and using the purchase order in the equipment on order file to complete the property record card, the purchase order will be placed in the equipment received file pending the receipt of the related invoice. Procedures with respect to the paying process are covered in this accounting manual.

b. Recording Cost and Quantity in Property Record Card

- (1) From a copy of the receiving report, properly filled out in accordance with 2a (above) together with gross cost as well as unit price, the property records clerk (as designated) will record the cost and quantity data onto the property record card. A concurrent action will be the recording of this cost in the asset and Furniture, fixtures and equipment-Contra credit accounts. A separate record card will be maintained for each category of equipment (such as chairs, tables, desks, etc.). The record card will contain the following data:

- (a) Date of receipt
- (b) Unit and gross cost of procurement
- (c) Quantity received
- (d) Quantity balance on hand
- (e) Dollar balance on hand
- (f) Average unit cost
- (g) Disposals--quantity and cost
- (h) Manufacturer's serial number or name

- c. A sample property record card is attached. This format is not a requirement. The data set out on the card, however, is necessary in order to meet the basic requirements of the property records system developed for BWP sponsors.
- (1) Prior to recording the data on to the property record card, it is essential that each piece of property be properly marked with a BWP number. The serial number of typewriters, adding machines, calculating machines, etc., is accepted as a control number in lieu of a BWP number. Property is to be identified as BWP because other equipment on the premises may belong (a) to the sponsor, or (b) purchased or secured under other programs in which the sponsor is involved (OEO, HEW, etc.).
 - (2) It is possible to reconcile the purchased property cost as recorded on the property record cards with the cost as recorded in the operating cost accounts.
 - (3) Freight costs, identified to nonexpendable property placed under record control will be added to the cost (per the property record card and the asset account) both gross cost and net cost of the related equipment. The capitalization of freight costs in this instance is limited to the initial receipt of the equipment to the location of the sponsor. The freight cost of any subsequent movements will be expensed.
 - (4) As property is added to a card record, a new average unit price will be developed, based on (a) the total quantity on hand and (b) the accumulative cost value including the most recent purchase. The most recent average developed will be used in adjusting the records where property has been disposed of.

3. PURCHASE OF USED EQUIPMENT

a. Receipt of Property

The procedure in this respect is the same as that set out for new equipment.

b. Recording Cost and Quantity on Property Record Card

Procedures are basically the same as outlined for the purchase of new property. Record the cost (net of discounts allowed) and date of acquisition per the invoice or SF 122 on the property record card.

4. RECEIPT OF GOVERNMENT EXCESS PERSONAL PROPERTY

a. Receipt of Property

The receipt of property will be supported by advance documentation indicating conditions under which the equipment is made available including the responsibility for repair. The tickler or advance copy must be annotated with the receipt data and be properly signed. In all cases, entries should not be recorded onto the property record card until evidence of receipt has been noted on the receiving report.

b. Recording Cost and Quantity on Property Record Card

The procedures with respect to the treatment of donated and excess property, be it used or new, follows the system established for 3b (above). Please note the entry on quantity received column of the property record card. The column is subdivided into two breakouts indicating (a) purchased--new, and (b) purchased--used, and excess. The entry, in this respect, is in the latter breakout.

5. Treatment of Disposals

a. The U.S. Department of Labor, Manpower Administration issuance, "Property Handbook for Contractors," dated September 1965, spells out the procedure with respect to disposal action. This issuance, made available to all BWP sponsors is not quoted in depth since it is considered as part of the total package made available under contract agreement. With specific reference to disposal action, the following is extracted to highlight this phase of the procedures.

- (1) No disposal may be made of Government property without authority of the Property Control Office.
- (2) Report of all cases of loss, damage or destruction of Government property shall be made to the Department of Labor as soon as the facts become known.

b. Recording Disposal Action

Disposal actions will be recorded in the Property Record Cards both as to quantity and total value. Concurrently record this action on the asset and Furniture, fixtures and equipment-Contra

credit account and/or Department of Labor - Property, of the general ledger. The cost value of the items disposed will be based on the average unit cost developed immediately prior to the disposal.

6. Physical Inventory Requirements

- a. Because of the relatively short duration of most of the BWP agreements, generally written for a period of one year or less, the only requirement with respect to a physical inventory is at the conclusion of the agreement. At that time a listing should be made from the property record cards, detailing by category of equipment all federally owned property.
- b. The inventory forms as spelled out in the "Property Handbook for Contractors" is filled out by the person taking the physical inventory. This person should not be the individual who (a) has the responsibility for the property record cards and (b) is the individual responsible for the property. The comments column is provided for reference as to the condition of the property and possibly the utilization value of the property with respect to continued use in a new project.
- c. Two individuals should work together in taking inventory, one calling out the serial or identification numbers while the other individual makes the notations on other listings. This listing, prepared in duplicate, should be made available to the auditors.

7. Reconciliation With General Ledger

- a. The adoption of a system of recording all equipment, under property control, into an asset account, offset by Furniture, fixtures and equipment - Contra credit account and/or Department of Labor - Property, assures a continuing tie-in of the property detail with the asset account in the general ledger.
- b. To assure a continuing position of tie-in control, it is recommended that the property record cards be proved to the general ledger asset account on a monthly basis. Thus, any differences will be narrowed down to transactions within a single month.

8. General

- a. Cost (new equipment) will always be recorded net of any discounts,

except when the discount is lost due to late payment.

- b. Improvements which materially increase the usefulness, productivity, or other value of nonexpendable property, or substantially extended its useful life shall be capitalized (added to property record card).
- c. There is set out below a proposed format of a property record card.

S DEPARTMENT OF LABOR
ANPOWER ADMINISTRATION

PROPERTY RECORD CARD

1. CONTRACT NO

3 LOCATION OF PROPERTY

CONTRACTOR (Name and Address)

5 DESCRIPTION (Mfg name, model, type, size, etc.)

PROPERTY TYPE

PROPERTY RECORD

DATE RECEIVED (d)	PURCHASE ORDER OR ACQUISITION DOC. NO. (1)	QUANTITY RECEIVED		SERIAL NUMBER (-)	QTY DISPOSED (f)	TOTAL ON HAND (st)	UNIT COST (bi)	TOTAL COST OR VALUE (i)	MFG DATE (If m/f net)	AVG UNIT COST (r)
		NEW (-)	USED OR EXCESS (-)							



A description of each column follows:

- (a) Date Received. Date of receipt of equipment
- (b) Purchase order or Document no. Indicate the number of the executed document authorizing the purchase of equipment or SF 122 for acquiring excess property.
- (c) New. The quantity of items which were purchased new.
- (d) Used or excess. The quantity of items which were purchased used or furnished by the Department of Labor.
- (e) Serial number. The serial number of the equipment.
- (f) Quantity disposed. Number of items of equipment disposed of by any method including transfers out, loss, or destruction.
- (g) Total on hand. Quantity on hand after recording the most recent action.
- (h) Unit cost. Based on new cost, net discount- if not new, the current replacement value - estimated if not known.
- (i) Total cost or value. Total cost of purchase net of discount. The total cost recorded should be verified by the multiplication of column (h) by quantity received. The freight cost also will be recorded in this column.
- (j) Avg. Unit Cost. Total value divided by column (g) total on hand.

PROPERTY LIST

(See instructions on reverse)

1. CONTRACT NO.

PREV. CONTRACT NO.

2. CONTRACTOR (Name and Address)

4. TYPE PROJECT (Check one)

- In School
- Out of School
- Summer
- Research
- Experimental & Demonstration
- On-the-Job Training
- Grant
- Other (Specify)
- Op. Mainstream
- New Careers
- Special Impact

3. CONTRACTOR'S PROPERTY REPRESENTATIVE

Name:

Address:

Telephone No:

Area Code:

5. PROPERTY IDENTIFICATION

QTY. REQ'D.	DESCRIPTION	TOTAL COST OR VALUE*	DEPRECIATION	RENTAL	% OF TIME FOR CONTR USE	NO. OF MONTHS REQ'D.	COST TO CONTRACT
(a)	(b)	(c)	(d)	(e)	(f)	(g)	(h)
OFFICE							
PROJECT							

* Contractor-owned

Contracting Officer Rep.

Approved:

SIGNATURE

DATE

Instructions for Completing the Property List, MA 726

1. Leave blank.* (To be completed by Contracting Officer's staff upon the assignment of contract number.)
2. Enter the contractor's full name and address with ZIP code.
3. Enter the name, address and telephone number of the individual who will be charged with the responsibility of acquiring, maintaining property records, and receipting (signing for) property for the contractor.
4. Check (X) the block applicable to your particular project, program, or study.
5. Complete the columns as follows:
 - a. Indicate how many of a particular item are required.
 - b. Describe the article as completely as possible; manufacturing name, model, type, size, etc.
 - c. Insert the cost, if purchase is anticipated. Insert the value, if contractor owned property. The amount should be the sum for quantity required in column (a). If contractor owned, place an asterisk beside the dollar amount.
 - d. Depreciation column is to reflect the useful life span of the equipment under consideration. For example, if a tractor had an expected life of 10 years when purchased, the figure 10 should be inserted in column (d).
 - e. If property rental is anticipated, indicate the total monthly cost for the line item.
 - f. Indicate whether the property will be used full time (100%) or part time (10%, 30%, 50%, etc.) during contract performance.
 - g. Indicate the number of months the property will be needed during entire life of contract. (Some may be needed during entire life of contract, while others may be needed for a specific phase.)
 - h. Cost to contract should be completed as follows:
 - (1) If purchase, column (h) should be the same as column (c).
 - (2) If rental, column (h) should reflect the monthly rental cost (e) times the number of months required (g).
 - (3) If contractor-owned equipment is used as the contractor's share of the cost, column (h) should reflect a computation of "value" (c), "depreciation" (d), "No. of Mo. Required" (g), and "% of Time for Contract Use" (f).

Ex: One year contract.

Tractor--value (c) = \$10,000

Expected life of Tractor--10 years (d)

Will use tractor 10% of time (f) for

6 months or $\frac{1}{2}$ yr. (g)

$\$10,000 (c) \div 10 \text{ yrs. (d)} = \$1,000 \times \frac{1}{2} \text{ yr. (g)} = \$500 \times 10\% (f) = \$50 (h)$

*If you have had a prior contract
insert previous contract number

III-10b

D. SUGGESTED CLASSIFICATION OF GROUPINGS

Property Record Card Equipment Control

ITEM

Furniture

CHAIR

Wood, walnut, rotary
Wood, walnut, str. leg, leather
Conference room, leather
Easy, leather
Davenport, leather
Typist, walnut
Typist, straight
Typist, unitized
Swivel, w/arms, unitized
Str. leg, w/arms, unitized
Swivel, wood, old

DESK

Executive, wood, walnut
Typist, wood, walnut, left comp.
Typist, wood, walnut, right comp.
Steel, flat top, double
Steel, F.T., typist, left comp.
Steel, F.T., typist, right comp.
Unitized, executive
Unitized, right comp.
Unitized, left comp.
Wood, F.T., old

TABLE

Wood, 24" x 18"
Wood, 18" x 18"
Wood, walnut, 72"
Wood, walnut, 60"
Wood, walnut, 36" x 24"
Wood, walnut, 96"
Wood, walnut, 120"
Wood, walnut, 144"
Wood, walnut, 36" x 48"
Wood, end
Wood, coffee
Steel, unitized, 45" x 24"
Steel, unitized, 60" x 34"
Steel, unitized, credenza

CABINET

File, steel, legal, 4 dr., w/lock
File, steel, legal, 4 dr., w/o lock
File, steel, letter, 4 dr., w/lock
File, steel, letter, 4 dr., w/o lock
File, steel, legal, 5 dr., w/lock
File, steel, legal, 5 dr., w/o lock
File, steel, letter, 5 dr., w/lock
File, steel, letter, 5 dr., w/o lock
File, steel, locator

MISCELLANEOUS

File, cardex, 5 dr.
File, cardex, 6 dr.
File, cardex, 7 dr.
Table, for cardex file
File, steel, map
Bookcase, wood, walnut, 12"
Bookcase, wood, walnut, 14"
Bookcase, wood, walnut, 16"
Bookcase, wood, nonsectional
Cabinet, wood, walnut, telephone
Cabinet, steel, lin. top, telephone,
unitized
Cabinet, steel, supply
Cabinet, wood, supply
Rack, wood, display
Rack, wood, magazine
Costumer, wood, walnut
Costumer, steel, 4 hook
Costumer, steel, 6 hat/cap
Drapes
Carpets
Lamp, weighted base
Lamp, executive

ITEM

Equipment

ADDING MACHINE

CALCULATOR

DICTATING MACHINE

Portable

Nonportable

DUAL DICT. AND TRANS.
MACHINE

DUPLICATING MACHINE

Wet Process

Dry Process

MULTIPLIER

Automatic

TRANSCRIBING MACHINE

TYPEWRITER

Manual

Electric

Portable

Standard

Executive

Automatic

MISCELLANEOUS

Time Stamp

Collating Machine

Camera

Tape Recorder

Cart, Mail

Truck, Hand

Drafting Machine

RECONCILIATION OF COSTS PER BWP SPONSOR'S
 DETAILED STATEMENT OF COSTS TO CASH DISBURSEMENT

January 31, 1966

Cash in bank--Beginning of month-----	---0---
Add: Funds received from BWP -- January 7, 1966-----	\$18,000.00
	<hr/>
Total-----	18,000.00
Less: Current month costs per BWP sponsor's detailed statement of costs-----	16,522.50
	<hr/>
	1,477.50
Add: Current month liability accruals for payroll-----	8,140.00
	<hr/>
Cash balance--End of month-----	9,617.50
	<hr/> <hr/>
Made up of regular checking account-----	\$9,617.50

BWP SPONSOR'S BALANCE SHEET AS OF JANUARY 31, 1966

Assets

Current Assets:

Cash in bank--Regular account----- \$9,617.50

Fixed Assets:

Furniture and fixtures and equipment - purchase----- 400.00

Furniture, fixtures and equipment -Contra credit account----- 400.00

---0---

Total assets-----\$9,617.50

Liabilities and Equity

<u>Current Liabilities:</u>	
Accounts payable-----	¹ \$1,477.50
Month-end accruals-----	8,140.00
	<hr/>
Total liabilities-----	9,617.50
<u>Equity:</u>	
Contribution by BWP-----	16,522.50
Current year costs chargeable to BWP -----	16,522.50
	<hr/>
Total equity-----	--0--
Total liabilities and equity-----	\$9,617.50

¹
Amount due Federal Government.

APPENDIX A

Flow Chart and Sample Set of Records

Set out below is a series of accounting transactions typical of a BWP operation. The treatment of the transactions are illustrated through the use of flow charts and sample journals, general ledgers, and related worksheets including the closeout of the books and a balance sheet after closing. A "Reconciliation of Costs Per BWP Sponsor's Detailed Statement of Costs to Check Disbursements" has also been developed. The accounting transactions and the source of original entry follow.

<u>Transaction</u>	<u>Source of Original Entry</u>
1. Bill BWP for an advance of funds----	General journal.
2. Receive advance of funds from BWP---	General journal.
3. Establish petty cash fund-----	Check disbursement journal.
4. Pay vendor for supplies received----	Check disbursement journal.
5. Pay vendor for office equipment received-----	Check disbursement journal.
6. Record purchase of office equipment in asset accounts and on property record cards-----	General journal.
7. Reimburse staff for official local travel expenses incurred-----	Petty cash register.
8. Reimburse staff member for purchase of incidental emergency supply needs-----	Petty cash register.
9. Record staff payroll-----	Payroll journal.
10. Record enrollee payroll-----	Payroll journal.
11. Record employer's cost of fringe benefits for staff and enrollees---	General journal.
12. Record monthly deposit with the Federal reserve-----	Check disbursement journal.
13. Pay rent, telephone, and utility bill-----	Check disbursement journal.
14. Total payroll journal columns-----	NA.
15. Post payroll journal totals to general ledger accounts-----	NA.
16. Record tax liabilities-----	General journal.
17. Total check disbursement journal totals-----	NA.
18. Post check disbursement journals to general ledger accounts -----	NA.

Transaction

Source of Original Entry

- 19. Total petty cash register columns-----NA.
- 20. Post petty cash register totals to general ledger accounts ----- NA.
- 21. Close petty cash fund-----General journal.
- 22. Prepare worksheet including preclosing trial balance and detailed statement of costs---- NA.
- 23. Record month-end accruals for payroll----- General journal.
- 24. Record closing entries-----General journal.
- 25. Prepare reconciliation of costs per BWP sponsor's detailed statement of costs to check disbursements----- NA.
- 26. Establish liability for funds refundable to the Federal Government and record in general ledger accounts----- General journal.
- 27. Complete Worksheet including closing entries, post closing Trial Balances, and Balance Sheet columns----- NA.

FLOW CHART
of Typical Accounting Transactions for BWP Sponsors

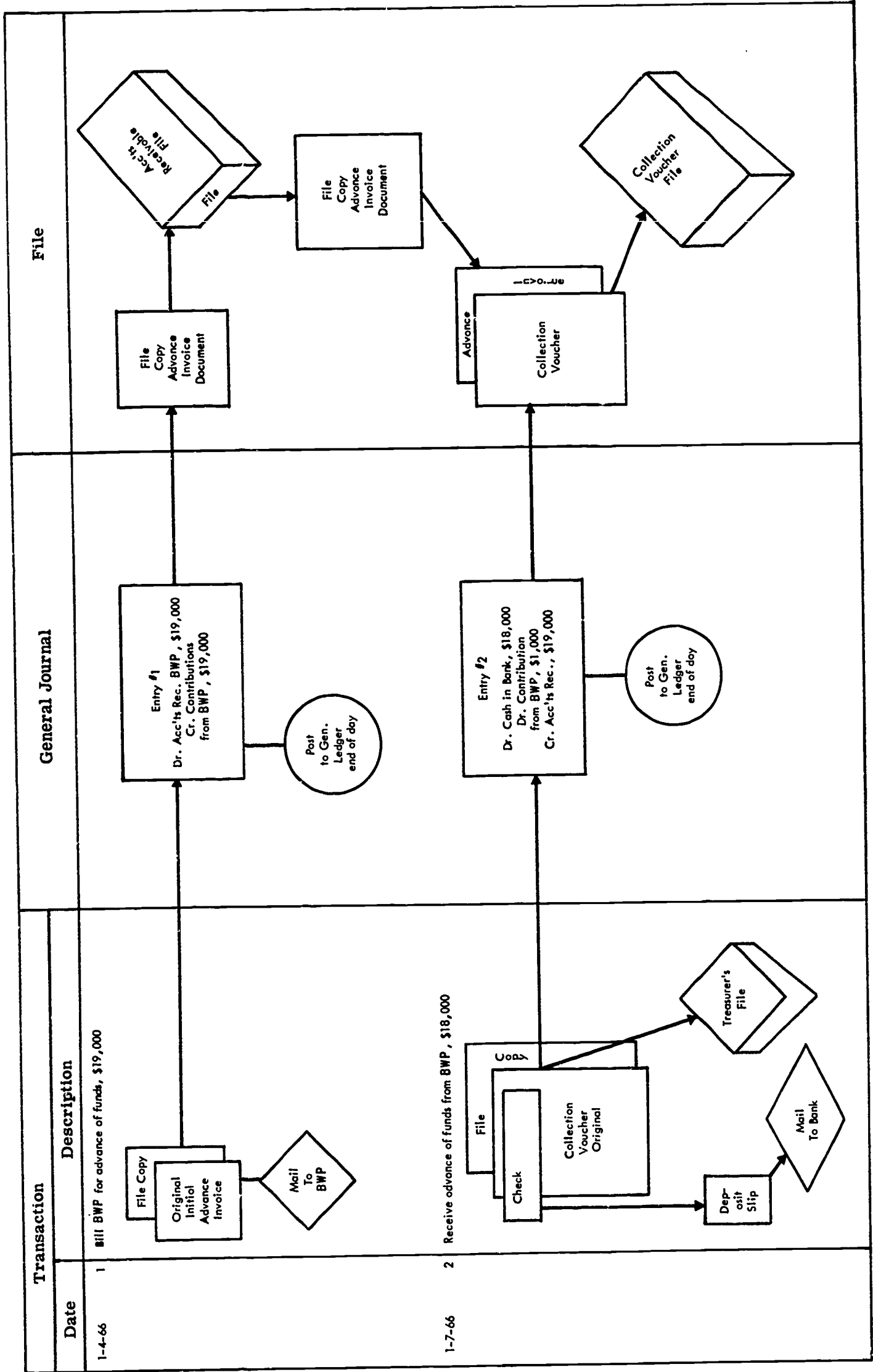

FLOW CHART of Typical Accounting Transactions for BWP Sponsors

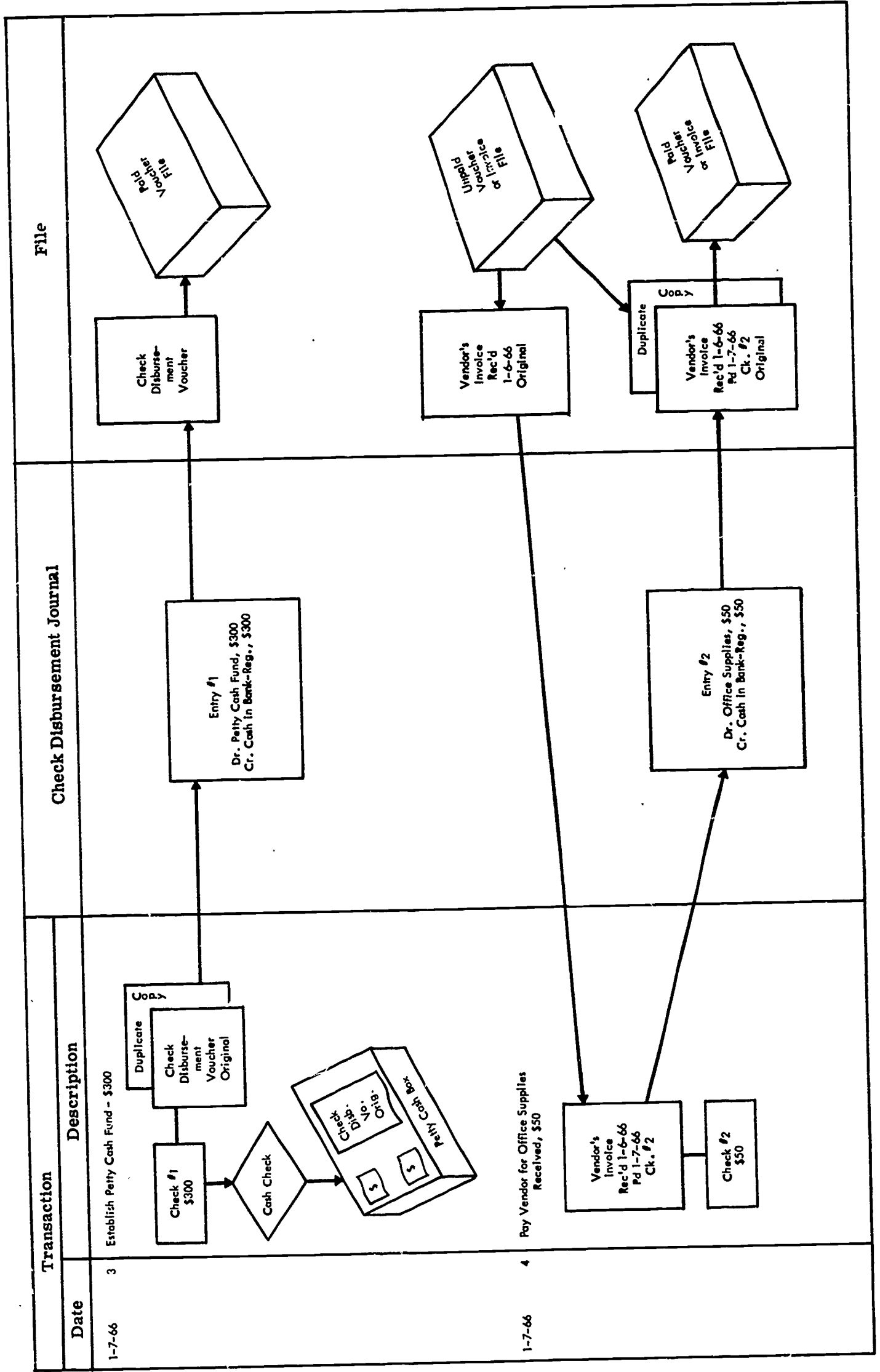

FLOW CHART
of Typical Accounting Transactions for BWP Sponsors

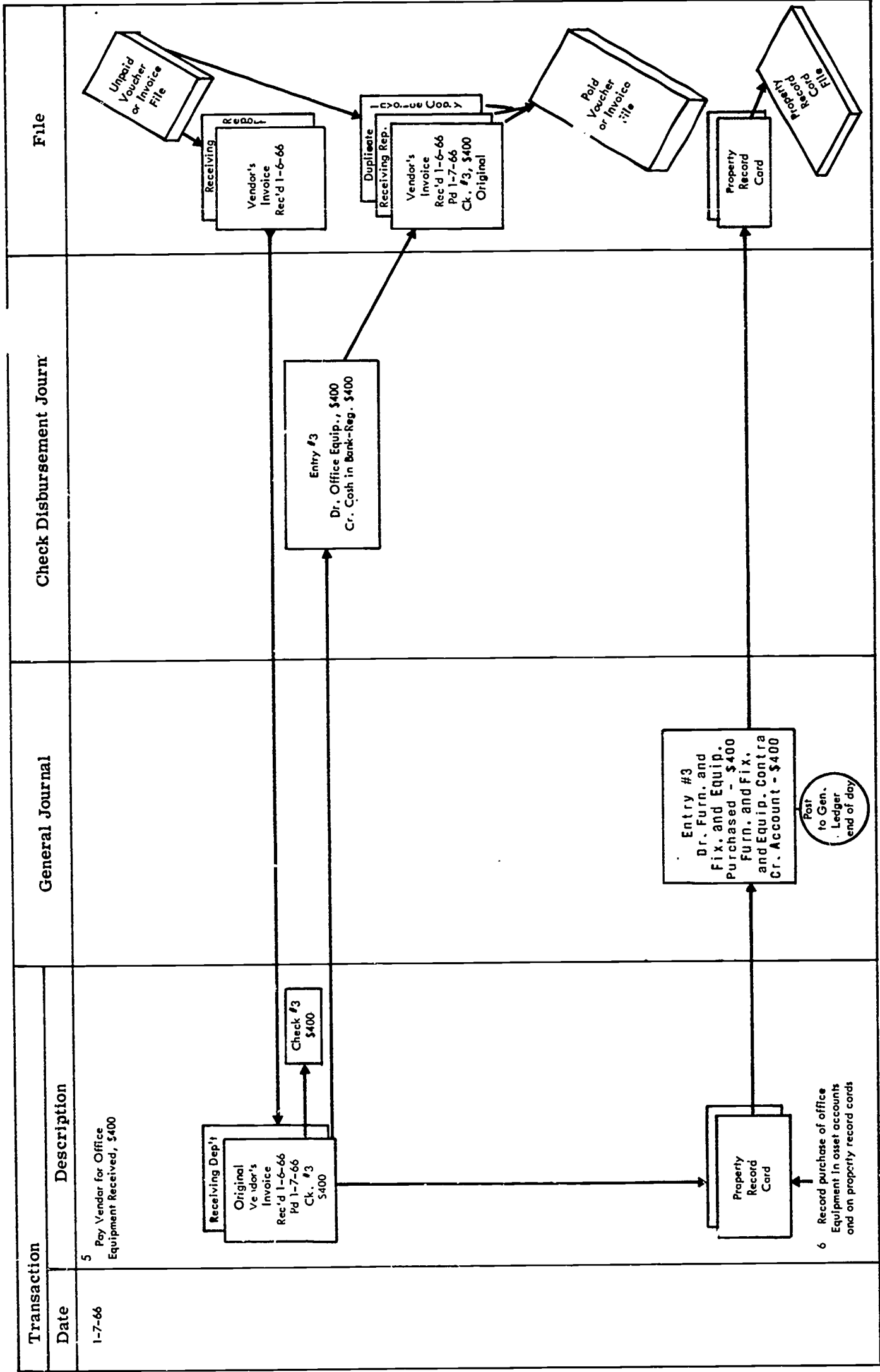

FLOW CHART
of Typical Accounting Transactions for BWP Sponsors

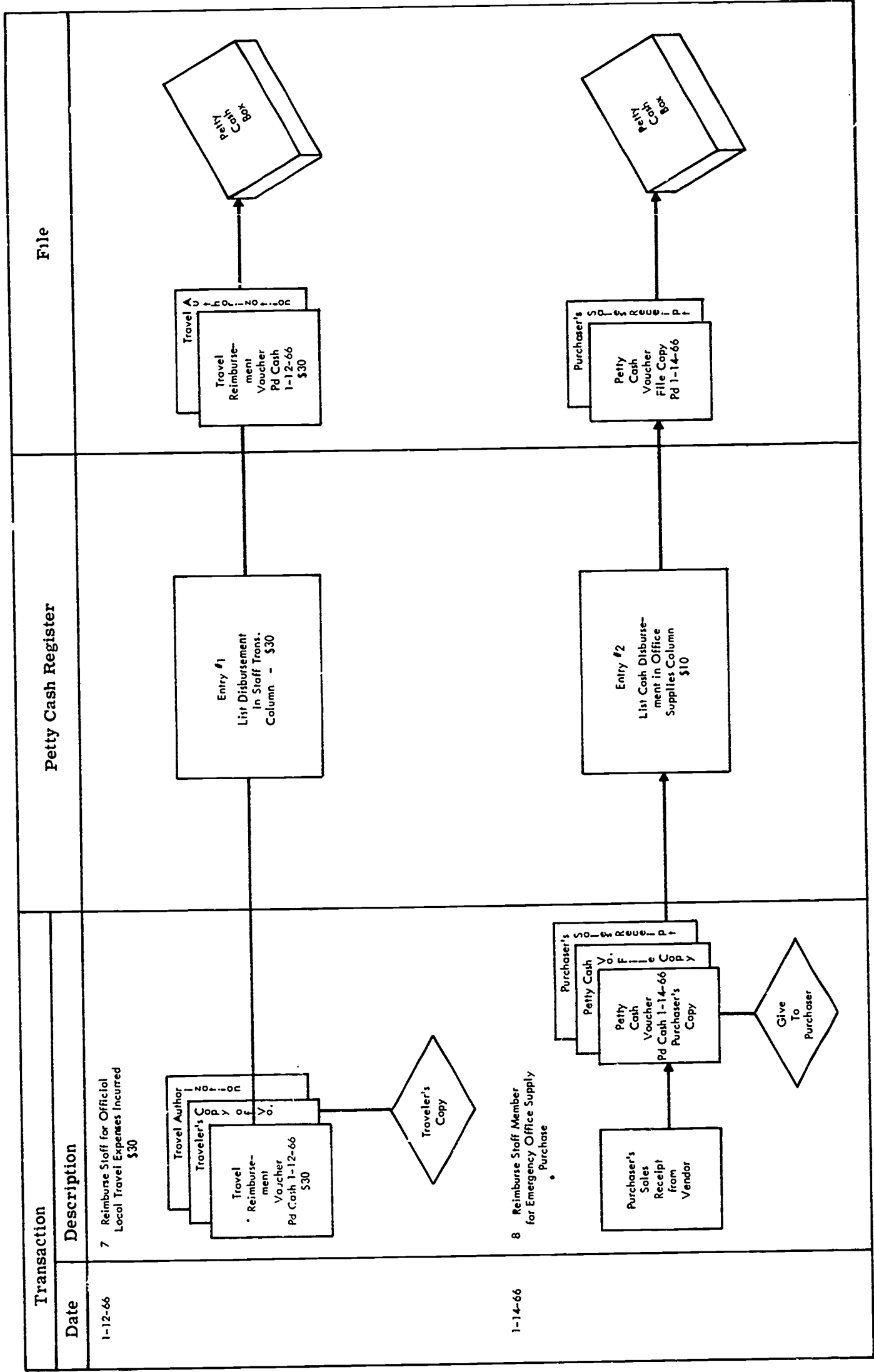

FLOW CHART
of Typical Accounting Transactions for BWP Sponsors

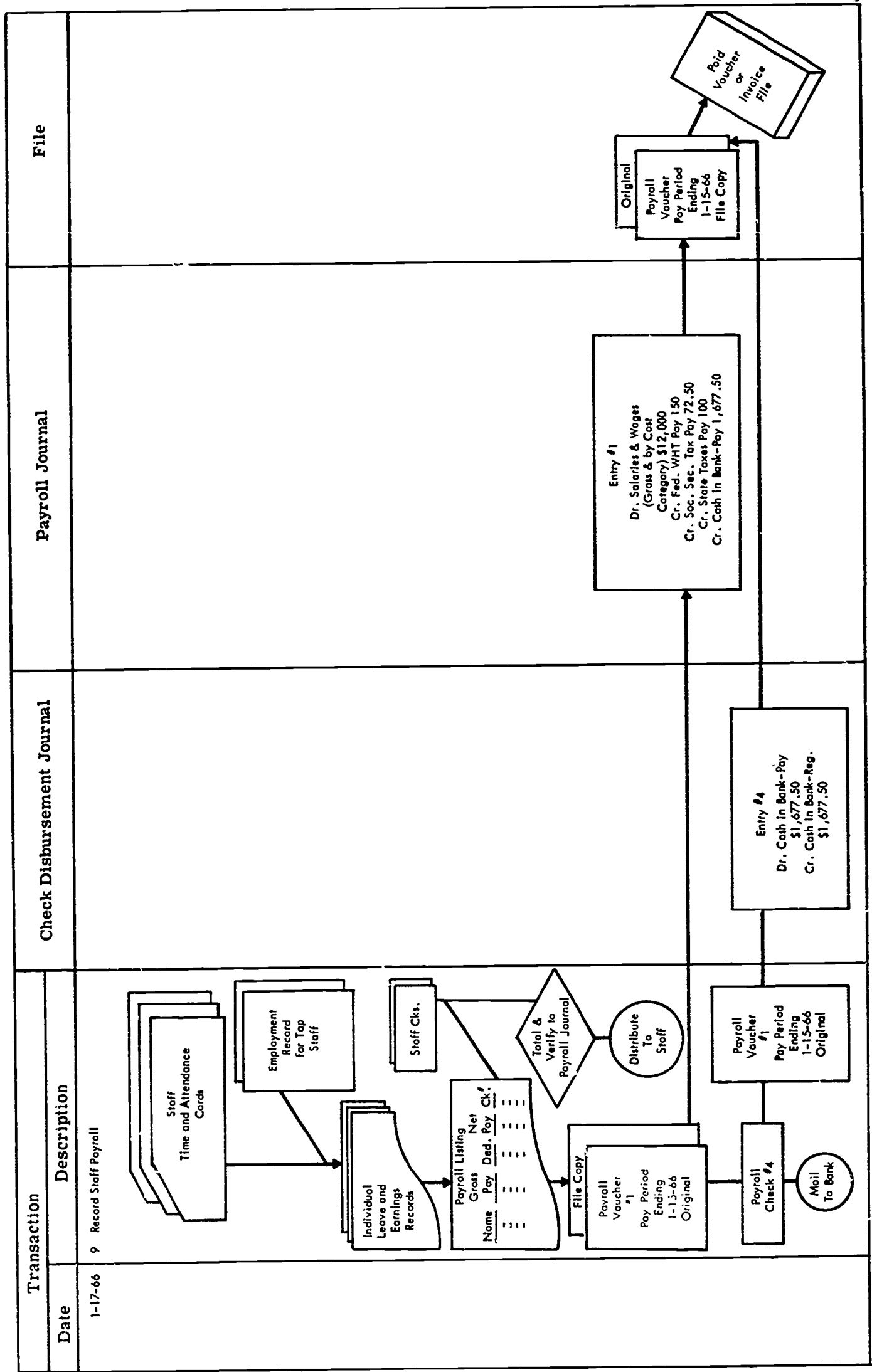

FLOW CHART
of Typical Accounting Transactions for BWP Sponsors

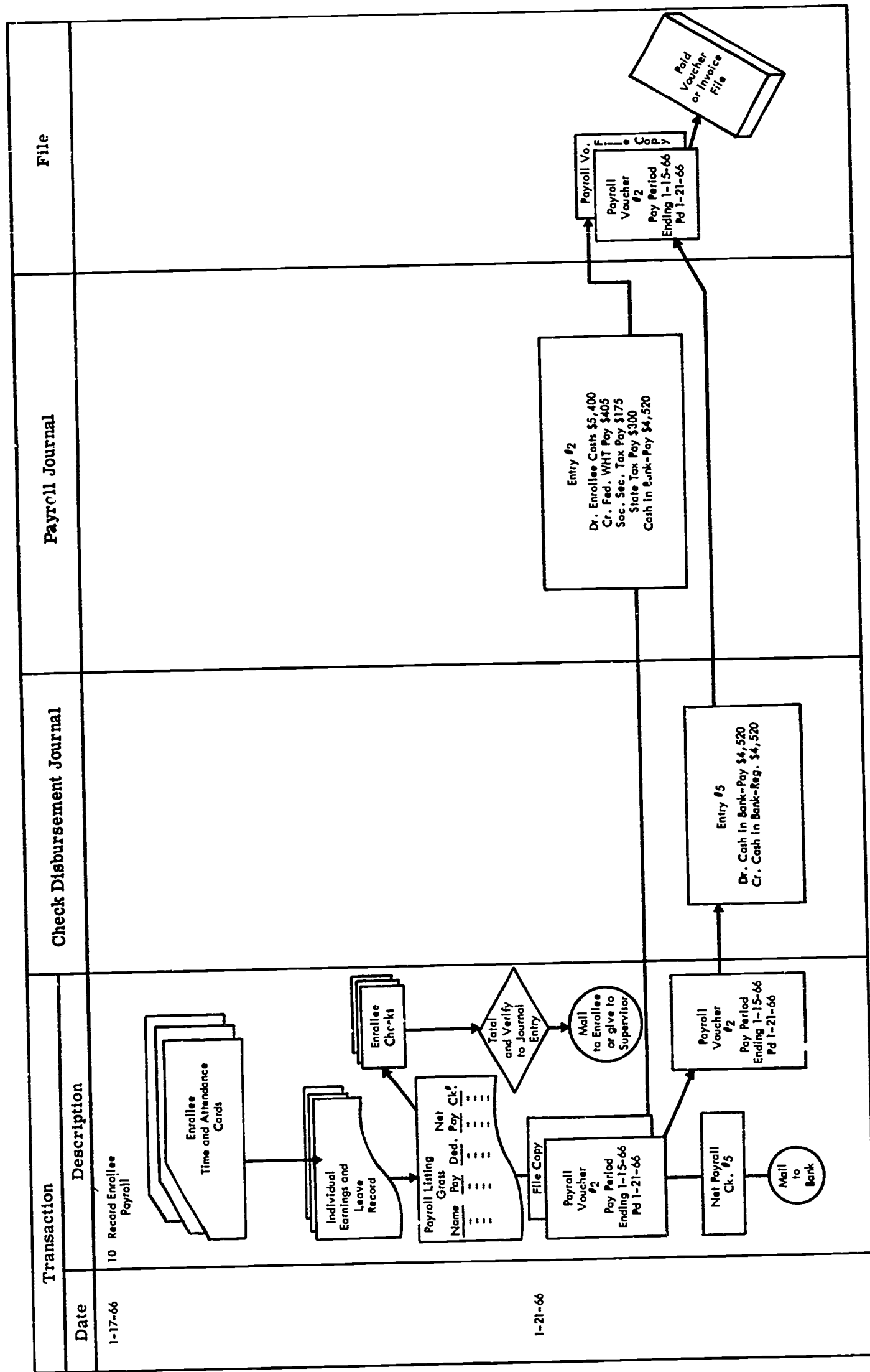

FLOW CHART
of Typical Accounting Transactions for BWP Sponsors

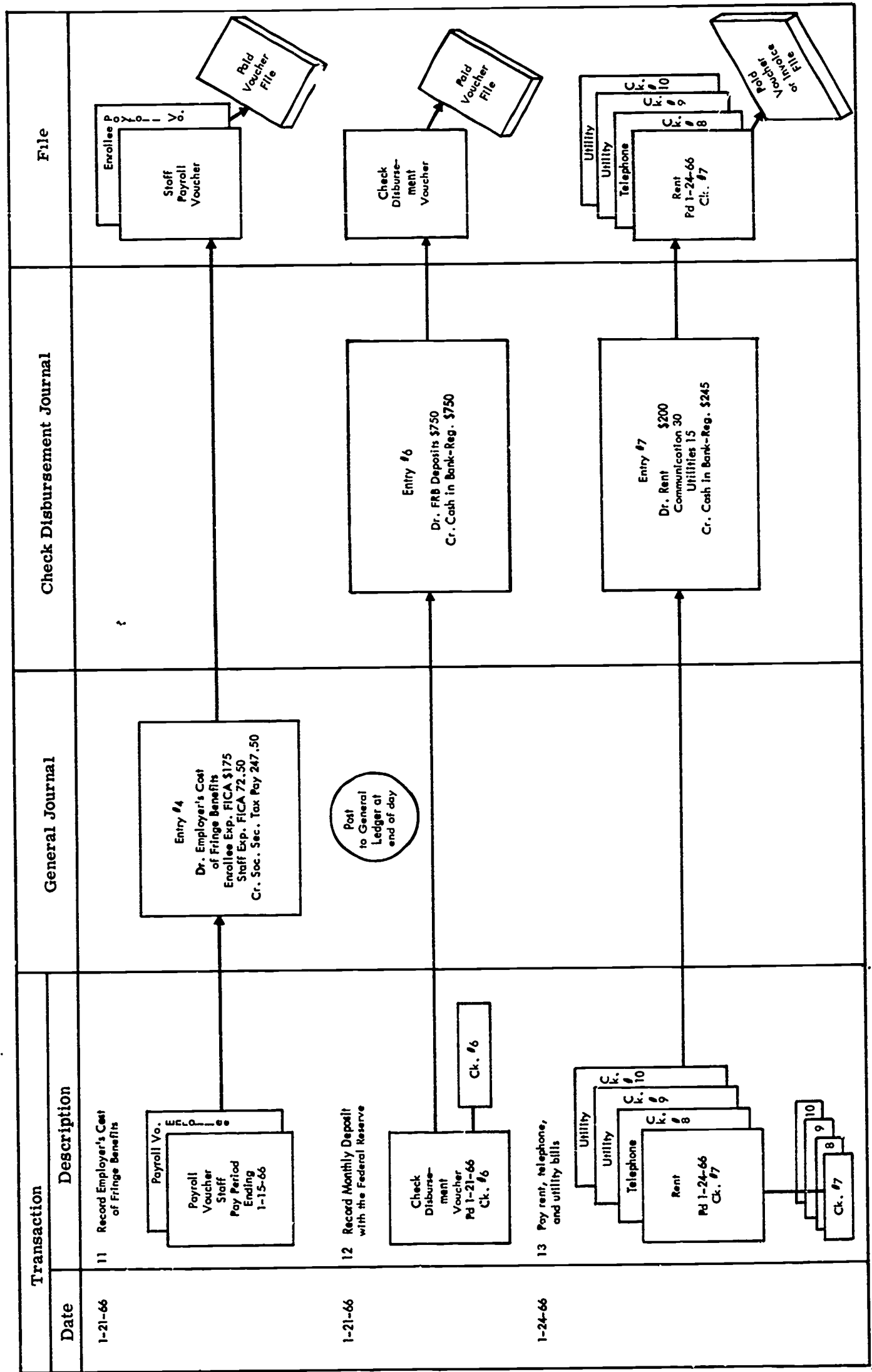

FLOW CHART
of Typical Accounting Transactions for BWP Sponsors

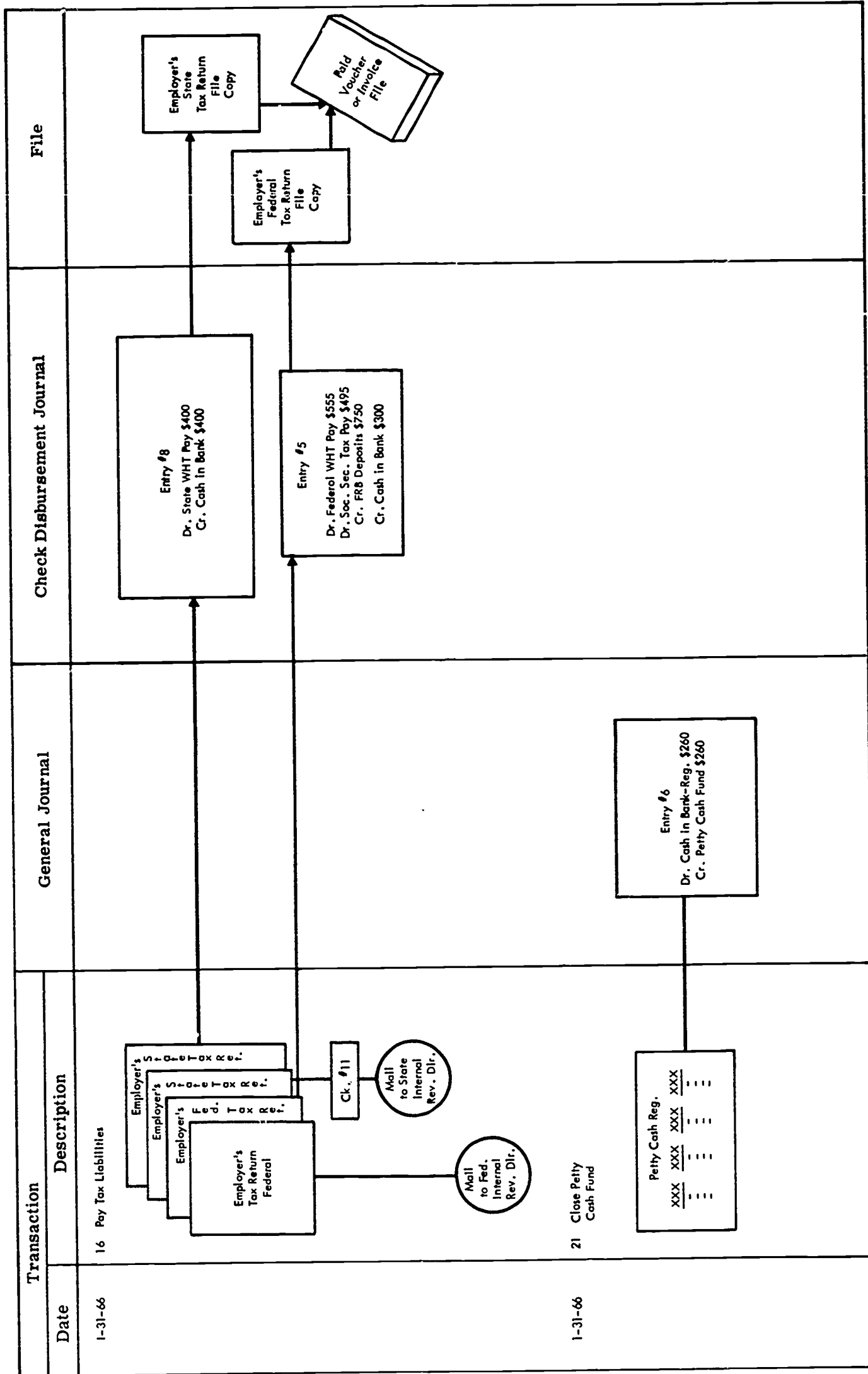

FLOW CHART
of Typical Accounting Transactions for BWP Sponsors

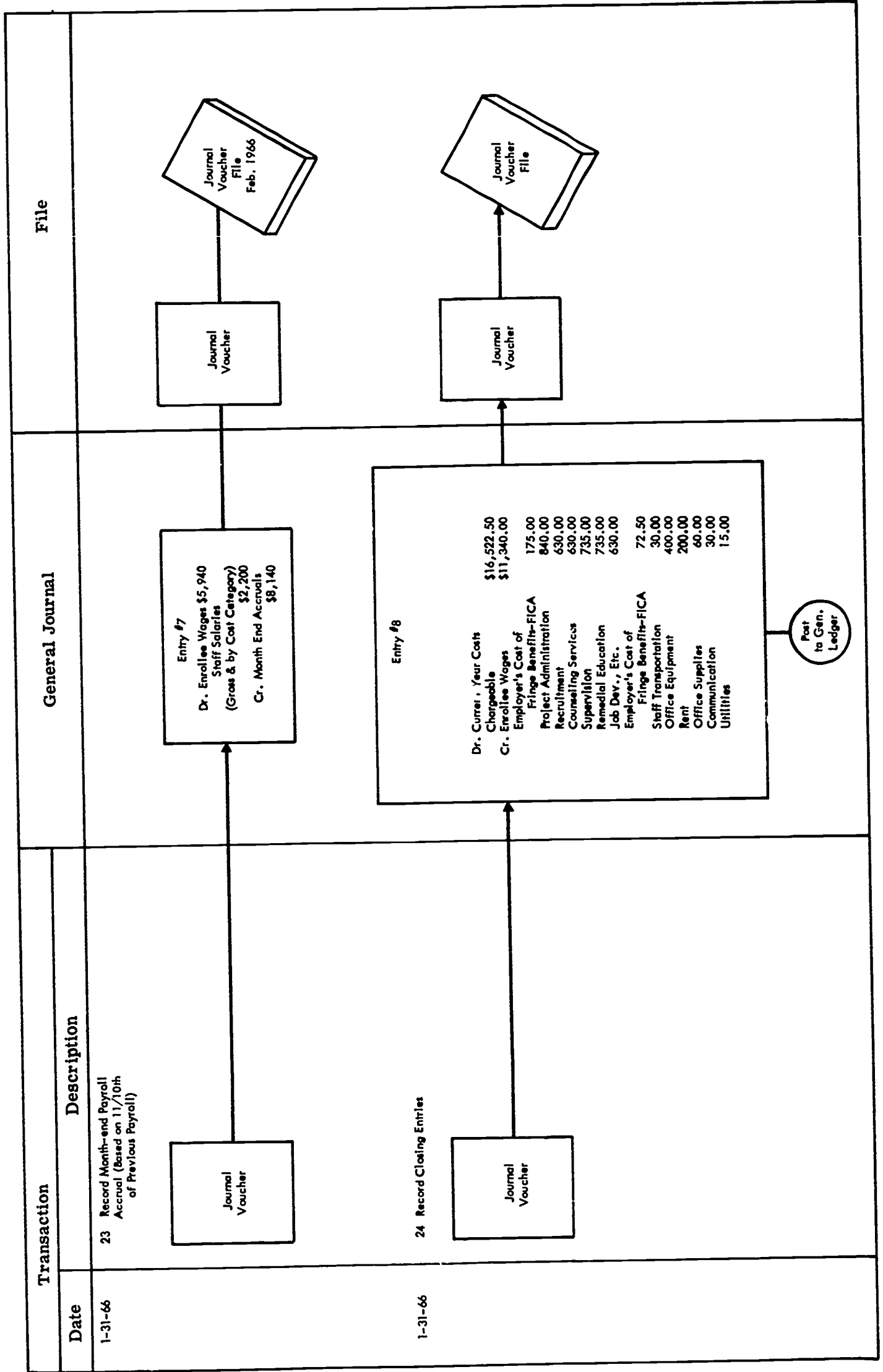

FLOW CHART
of Typical Accounting Transactions for BWP Sponsors

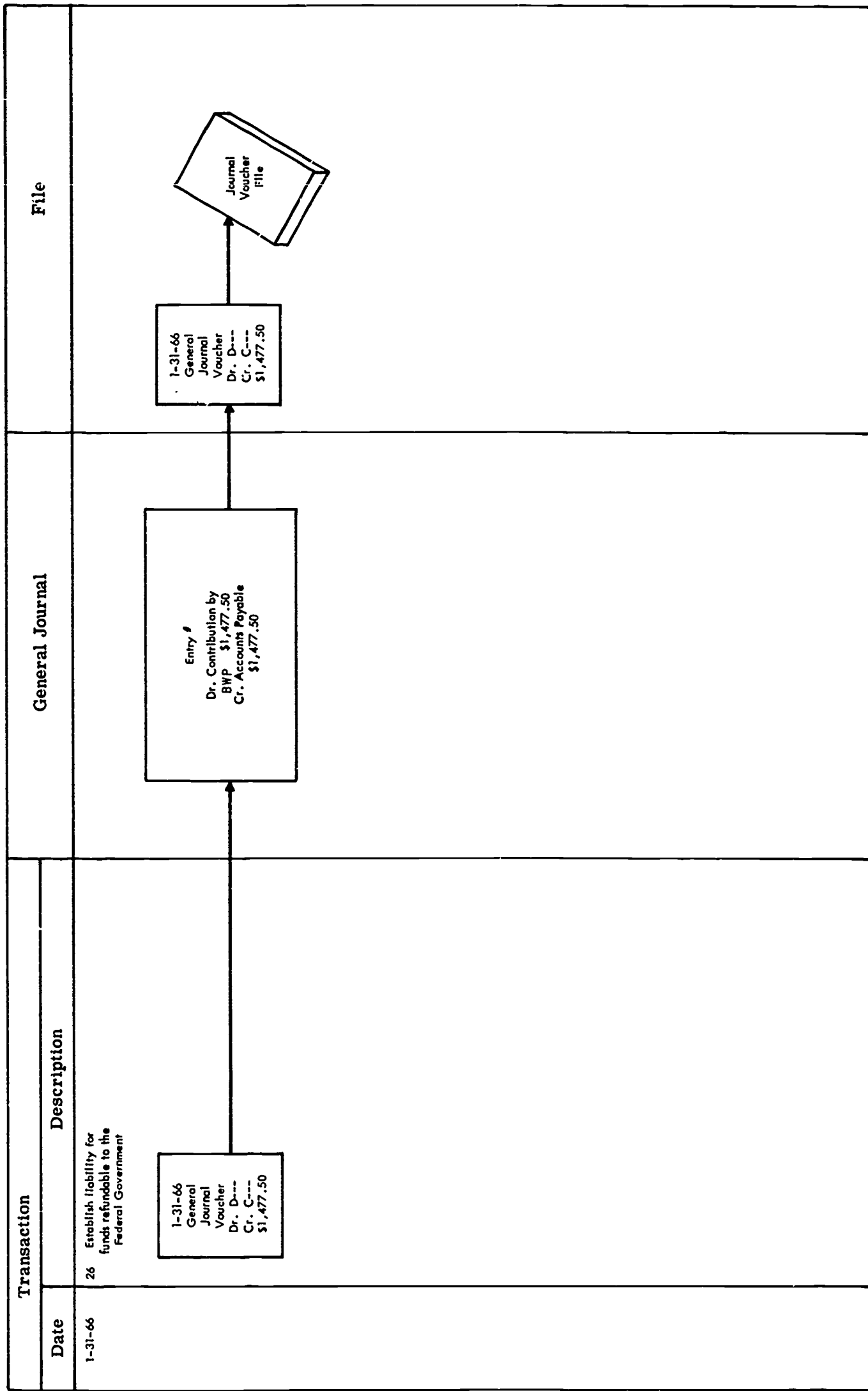

General Journal

Month of January 1966
Page 1

	Date	Entry	Debit	Credit
①	1-4-66	Accounts Receivable - BWP	19000 00	
		Contributions from BWP		19000 00
		To record request for advance of funds from BWP		
②	1-7-66	Cash in Bank - Regular	18000 00	
		Contributions from BWP	1000 00	
		Accounts Receivable - NYC		19000 00
		To record receipt of funds from BWP		
③	1-7-66	Furniture and Fixtures and Equipment	400 00	
		Furniture and Fixtures & Equip. - Contra Credit Acct.		400 00
		To establish asset accounts for equip.		
④	1-21-66	Employer's Cost Fringe Benefits FICA (Enrollees)	175 00	
		Employer's Cost of Fringe Benefits FICA (Staff)	72 50	
		Social Security Taxes Payable		247 50
		To record employer's portion of Social Security Taxes for pay period 1-15-66		

General Journal

Month of Jan 1966

Page 2

	Date	Entry	Debit	Credit
⑤	1-31-66	Federal Withholding Taxes Payable	555 00	
		Social Security Taxes Payable	495 00	
		FRB Deposits		1050 00
		To record payment of tax liabilities		
⑥	1-31-66	Cash in Bank -- Regular	260 00	
		Petty Cash Fund		260 00
		To transfer Petty Cash Fund to Regular checking Account		
⑦	1-31-66	Enrollee Wages	594 00	
		Project Administration	440 00	
		Recruitment	330 00	
		Counseling Services	330 00	
		Supervision	385 00	
		Remedial Education	385 00	
		Job Development, etc.	330 00	
		Month-end accrual to establish month-end payroll accrual based on $\frac{11}{10}$ ths of gross cost of pay period ending 1-15-66		8140 00

General Journal

Date			Debit	Credit
(8)	1-31-66	Current Year Costs Chargeable to BWP	16522 50	
		Enrollees Wages		11340 00
		Employers Cost of Fringe Benefits FICA Enrollees		175 00
		Project Administration		840 00
		Recruitment		630 00
		Counseling Services		630 00
		Supervision		735 00
		Remedial Education		735 00
		Job Development, etc.		630 00
		Employer's Cost of Fringe Benefits FICA Staff		72 50
		Staff Transportation		30 00
		Office Equipment - Purchased		400 00
		Rent		200 00
		Office Supplies		60 00
		Communication		30 00
		Utilities		15 00
		To record costs chargeable to BWP and closing entries		
(9)	1-31-66	Contributions by BWP	1477 50	
		Accounts Payable		1477 50
		To establish liability for funds refundable to the Federal Government		

Payroll Journal

Month: January 1966

Date	Payroll voucher No.	(Credit) Cash in bank	Staff costs								(Credit) Federal with- holding tax payable	(Credit) Social Security tax payable	(Credit) State tax payable	(Credit) Other deduction	
			Project administra- tion	Recruitment and selection	Supervision	Counseling service	Remedial education	Job development	Other services	Enrollee costs					
1-21-66	1	1,677.50	400.00	300.00	350.00	300.00	350.00	300.00							
1-21-66	2	4,520.00													5,400.00
1-31-66	Totals	6,197.50	400.00	300.00	350.00	300.00	300.00	350.00	300.00	300.00					5,400.00

U.S. DEPARTMENT OF LABOR
BUREAU OF ADMINISTRATION

PROPERTY RECORD CARD

1 CONTRACT NO

3 LOCATION OF PROPERTY

CONTRACTOR (Name and Address)

PROPERTY TYPE

5 DESCRIPTION (Mfg name, model, type, size, etc.)

PROPERTY RECORD

DATE RECEIVED	PURCHASE ORDER OR ACQUISITION DOC NO	QUANTITY RECEIVED		SERIAL NUMBER	QTY DISPOSED	TOTAL ON HAND	UNIT COST	TOTAL COST OR VALUE	MFG DATE	AVG UNIT COST
		NEW	USED OR EXCESS							
1-7-67	8650	1		A468912		1	\$200.00	\$200.00		\$200.00

MA 727

SAMPLE GENERAL LEDGER ACCOUNTS

Cash in Bank -- Regular

Account No 1010 Month of Jan 1966

Page 1

Date		Reference	Debit				Date		Reference	Credit									
1966 Jan	7	Gen. Journal Entry #2	1	8	0	0	00	1966 Jan	31	Check Disb. Journal			8	6	4	2	50		
	31	Gen. Journal Entry #6			2	6	0	00											
			1	8	2	6	0	00		31	Balance			8	6	4	2	50	
			1	8	2	6	0	00						9	6	1	7	50	
Feb	1	Balance												1	8	2	6	0	00

Accounts Payable

Account No 1270

Month of Jan 1966

Page 14

Date		Reference	Debit				Date		Reference	Credit							
								1966 Jan	31	Gen. Journal Entry #9			1	4	7	7	50

Contributions by BWP

Account No. 1410

Month of Jan 1966

Page 16

Date		Reference	Debit				Date		Reference	Credit								
1966 Jan	7	Gen. Journal Entry #2		1	0	0	00	1966 Jan	4	Gen. Journal Entry #1			1	9	0	0	00	
	31	Gen. Journal Entry #9	1	1	4	7	50		31	Gen. Journal Entry #9			1	4	7	7	50	
			1	6	5	2	2	50										
			1	9	0	0	00	Feb	1				1	9	0	0	00	
								Feb	1	Balance			1	6	5	2	2	50

SAMPLE GENERAL LEDGER ACCOUNTS

Current Year Costs Chargeable to BWP Account No 1420 Month of January 1966

Date		Reference	Debit					Date		Reference	Credit									
1966 Jan	31	General Journal	# 8	1	6	5	2	2	50											

Enrollee Wages Account No 1601 Month of Jan 1966

Date		Reference	Debit					Date		Reference	Credit										
1966 Jan	31	Payroll Journal		5	4	0	0	00	1966 Jan	31	Gen Journal Entry	# 8	1	1	3	4	0	00			
	31	Gen Journal Entry	# 7	5	9	4	0	00		31											
				1	1	3	4	0													
				1	1	3	4	0	00												

Office Equipment Account No 1661 Month of Jan 1966

Date		Reference	Debit					Date		Reference	Credit									
1966 Jan	31	Check Disb Journal		4	0	0	00	1966 Jan	31	Gen Journal Entry	# 8									

BWP Sponsors

Worksheet I
as at Jan 31, 1966

Account No.	Account Name	Pre-Closing Trial Balance		BWP Sponsor Debit		Closing Entries	
		Dr	Cr	Dr	Cr	Dr	Cr
10 10	Cash in Bank - Regular	9617 50					
10 20	Cash in Bank - Payroll	-0-					
10 30	Accounts Receivable - BWP	-0-					
10 40	Petty Cash Fund	-0-					
11 10	Deposits with Fed. Reserve Bank	-0-					
12 01	Furn, Fix, Equipment	400 00					
12 02	Furn. fix. & Equip - Contra. Cr. Acct.		400 00				
13 10	Fed WH Taxes Payable		-0-				
13 20	Soc. Sec Taxes Payable		-0-				
13 30	State WH Taxes Payable		-0-				
13 70	Accounts Payable		-0-				
13 80	Month End Accrual		8140 00			(9)	1477 50
14 10	Contribution by BWP		118000 00			(8)	16522 50
14 20	Cur Yr Costs Chargeable to BWP	-0-					
16 01	Enrollee Wages	11340 00			11340 00		
16 10	Emp Cost of Fringe Benefits	475 00			175 00		
16 11	FICA	175 00			-		
16 30	Salaries and Wages	-			4200 00		
16 31	Project Administration	840 00			840 00		
16 32	Recruitment	630 00			630 00		
16 33	Counseling Services	630 00			630 00		
16 34	Supervision	735 00			735 00		
16 35	Remedial Education	735 00			735 00		
	Sub Totals	251	26540 00		15085 00		18000 00
						(9)	1477 50
						(8)	16522 50
						(8)	11340 00
						(8)	175 00
						(8)	175 00
						(8)	840 00
						(8)	630 00
						(8)	630 00
						(8)	735 00
						(8)	735 00
							16562 50

BWP Sponsors

Worksheet II
as at Jan 31, 1966

Account No.	Account Name	Post Closing Trial Balance		Balance Sheet	
		Dr	Cr	Dr	Cr
10 10	Cash in Bank- Regular	9617 50		9617 50	
10 20	Cash in Bank- Payroll	-0-			
10 30	Accounts Rec. - BWP	-0-			
10 40	Petty Cash Fund	-0-			
11 10	Deposits with Fed. Reserve Bk.	-0-			
12 01	Furniture, Fix. & Equipment	400 00		400 00	
12 02	Furn. Fix. & Equip. - Contra. Cr. Acct.		420 00		400 00
13 10	Fed WH Taxes Payable		-0-		
13 20	Social Sec. Taxes Payable		-0-		
13 30	State WH Taxes Payable		-0-		
13 70	Accounts Payable		1477 50		1477 50
13 80	Month End Accrual		8140 00		8140 00
14 10	Contribution by BWP		16522 50		16522 50
14 20	Cur. Yr. Costs Chargeable to BWP	16522 50		16522 50	
16 01	Enrollee Wages	-0-			
16 10	Emp. Cost of Fringe Benefits	-0-			
16 11	FICA	-0-			
16 30	Salaries and Wages	-0-			
16 31	Project Administration	-0-			
16 32	Recruitment	-0-			
16 33	Counseling Services	-0-			
16 34	Supervision	-0-			
16 35	Remedial Education	-0-			
	Sub Total	26540 00	26540 00	26540 00	26540 00

All Bureau of Work Programs sponsors have assured the U.S. Government that no one enrolled in a BWP project will be discriminated against because of race, creed, color, or national origin.

CIVIL RIGHTS UNDER FEDERAL LAW

This means:

- ◆ That no benefits or services may be denied any enrollee because of his color, the country in which he or his parents were born, or his religion;
- ◆ that he may not be segregated or treated any differently than any other enrollee because of his race, color, religion, or national origin while he is being registered, interviewed, counseled, or tested; or while he is working or attending classes as part of the project;
- ◆ that he must be provided an equal chance to use all facilities available on the project.

If an enrollee is denied any of these opportunities, he has been instructed to talk the matter over with his supervisor. He also has the option to write to the Regional Office of the Bureau of Work Programs or to the Administrator, Bureau of Work Programs, U.S. Department of Labor, Washington, D. C., if he feels that his complaint has not been resolved to his satisfaction within 90 days.

REGIONAL OFFICES BUREAU OF WORK PROGRAMS

REGION I - NORTHEAST

Connecticut
Maine
Massachusetts
New Hampshire
New Jersey
New York
Puerto Rico
Rhode Island
Vermont
Virgin Islands

J. Terrell Whitsitt, Director
341 9th Avenue Room 912
New York, New York 10001
(212) 971-7565

REGION II - MID-ATLANTIC

Delaware
District of Columbia
Kentucky
Maryland
North Carolina
Pennsylvania
Virginia
West Virginia

William T. Davies, Director
Vanguard Building
Room 702
1111 20th Street, N. W.
Washington, D. C. 20036
(202) 386-4224

REGION III - SOUTHEAST

Alabama
Florida
Georgia
Mississippi
South Carolina
Tennessee

William Harris, Director
1371 Peachtree Street, N.E.
Room 636
Atlanta, Georgia 30309
(404) 526-5887

REGION IV - MID-WEST

Illinois
Indiana
Michigan
Minnesota
Ohio
Wisconsin

Regional Director
219 S. Dearborn Street
Room 2409
Chicago, Illinois 60604
(312) 828-6942

REGION V - SOUTHWEST

Arkansas
Louisiana
New Mexico
Oklahoma
Texas

William Bailey, Director
Mayflower Bldg. Room 314
411 North Akard Street
Dallas, Texas 75201
(214) 749-2952

REGION VI - MOUNTAIN PLAINS

Colorado
Idaho
Iowa
Kansas
Missouri
Montana
Nebraska
North Dakota
South Dakota
Utah
Wyoming

Regional Director
Federal Office Bldg. Room 3000
911 Walnut Street
Kansas City, Missouri 64106
(816) FR 4-3881

REGION VII - FAR WEST

Alaska
Arizona
California
Guam
Hawaii
Nevada
Oregon
Washington

Walter Griffin, Regional Director
450 Golden Gate Avenue
Room 10054
San Francisco, Calif. 94102
(415) 556-1542